

## MIKE4-CAN



**REMBE® Research+Technology Center GmbH**

Zur Heide 39, D-59929 Brilon, Germany

[www.rembe-rtc.de](http://www.rembe-rtc.de) [info@rembe-rtc.de](mailto:info@rembe-rtc.de)

**Cesana AG**

Baiergasse 56, CH-4126 Bettingen, Switzerland

[www.cesana-ag.ch](http://www.cesana-ag.ch) [info@cesana-ag.ch](mailto:info@cesana-ag.ch)

Author: Christoph Cesana

**MIKE3-CAN**

New and improved version of the previous MIKE3

Test condition: atmospheric

**MIKE4-CAN**

Extended apparatus for tests under the following conditions:

Atmospheric, high temperature, reduced oxygen content

- 1. Fundamentals ..... 2
  - 1.1 Introduction ..... 2
  - 1.2 Influencing quantities ..... 2
  - 1.3 Test procedure ..... 8
  - 1.4 Test apparatus MIKE 4 ..... 14
- 2. Installation ..... 20
  - 2.1 Apparatus ..... 20
  - 2.2 PC-Hardware ..... 22
  - 2.3 PC-Software ..... 23
- 3. Operation ..... 26
  - 3.1 Program start ..... 26
  - 3.2 Main screen ..... 26
  - 3.3 MIKE - Files ..... 29
  - 3.4 Test procedure ..... 31
  - 3.5 Test condition ..... 36
  - 3.6 Tables ..... 40
  - 3.7 Calibration ..... 41
- 4. Utilities ..... 42
  - 4.1 Report ..... 42
  - 4.2 Translations ..... 43
  - 4.3 Export ..... 45
  - 4.4 Info ..... 45
  - 4.5 Update ..... 46
  - 4.6 Flash-Programming ..... 47
- 5. Check the MIKE ..... 48
  - 5.1 Error messages ..... 48
  - 5.2 Check Ignition ..... 49
  - 5.3 Check IO - Port ..... 50
  - 5.4 System Timing ..... 51
  - 5.5 Temperature recording ..... 52
- 6. References ..... 54



Please read this note!



Attention: Please read this safety instruction carefully!

## 1. Fundamentals

### 1.1 Introduction

For an assessment of the hazard situation in dust-processing installations, knowledge of the minimum ignition energy is indispensable. This value can possibly determine the extent and hence the cost of protective measures.

The minimum ignition energy (MIE) is understood to mean the lowest energy value of a high-voltage capacitor discharge required to ignite the most ignitable dust/air mixture. The dust concentration and the ignition delay time must be systematically varied until a minimum value of the ignition energy is found. With MIKE 3 CAN all tests are performed at atmospheric pressure and room temperature.

### 1.2 Influencing quantities

Detailed investigations have shown that the minimum ignition energy of a combustible dust is influenced by the following parameters:

#### 1.2.1 Inductance in the discharge circuit

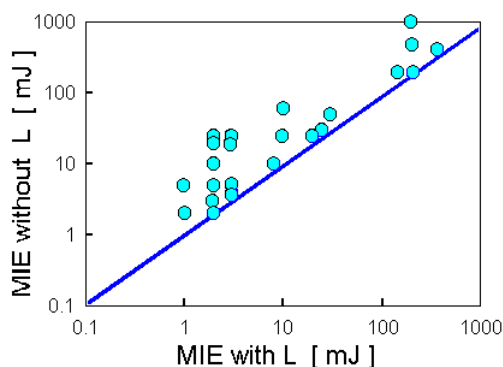
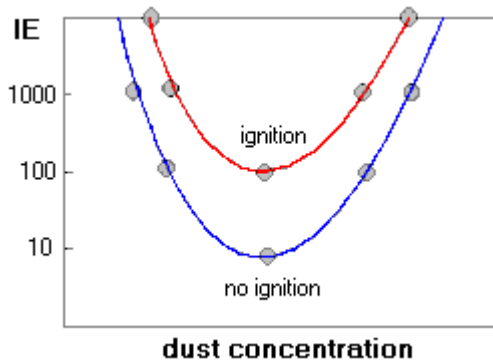

Fig. 1.2.1:  
Influence of the Inductance on  
the minimum ignition energy

By definition, minimum ignition energy data refer to protracted capacitor discharges. These are generally clearly more incendive than purely capacitive discharges. The results obtained under such conditions can only be applied to operational conditions if the capacitors occurring in plant installations are also discharged via an inductance. Hence, if the incendivity of electrical discharges -especially of electrostatic discharges - with regard to dust/air mixtures is to be assessed, the minimum ignition energy must also be determined without an inductance in the discharge circuit. As Fig. 1.2.1 shows, the effect of this influencing factor is not straightforward, but varies and is dependent on the type of dust.

1.2.2 Dust concentration



There is a parabolic relation between the dust concentration and the ignition energy. The MIE has therefore to be determined over a wide range of dust concentrations.

Fig. 1.2.2: Influence of the dust concentration on the ignition energy

1.2.3 Turbulence, ignition delay time

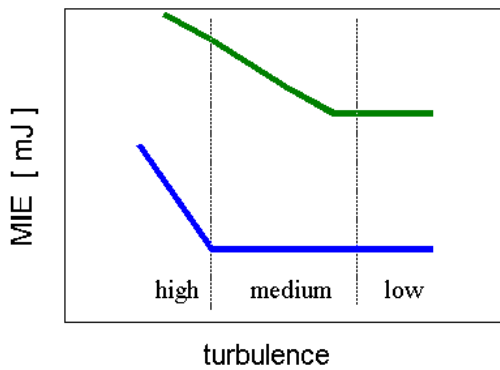
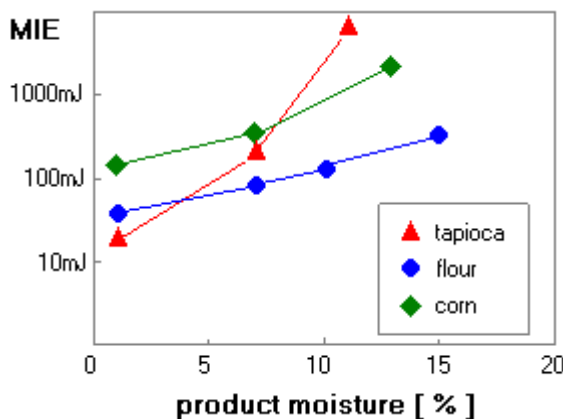

Fig. 1.2.3: Influence of ignition delay time on the minimum ignition energy

Easily the simplest measure of the turbulence of the dust/air mixtures is the ignition delay time  $t_v$  between actuation of the outlet valve and the sparkover. Short ignition delay times result in a high turbulence, long delay times in a low turbulence. The determination of the MIE should be performed with as low a turbulence as possible. If times are too long, separation of the dust can occur and the result is no longer meaningful. The optimum ignition delay time which results in the lowest value of the MIE is not constant, but depends on the dust sample. The ignition delay time must therefore be varied step by step until the minimum value of the ignition energy is found.

1.2.4 Product moisture (water content)



As the adjacent plot shows, the influence of the moisture content on the minimum ignition energy of a dust depends on the dust. In general, it appears that below 5% the influence is slight, whereas above 10% the value of the minimum ignition energy is increased by around 1 (one) power of ten or more.

Fig. 1.2.4: Influence of the moisture content on the minimum ignition energy

1.2.5 Particle size, median value

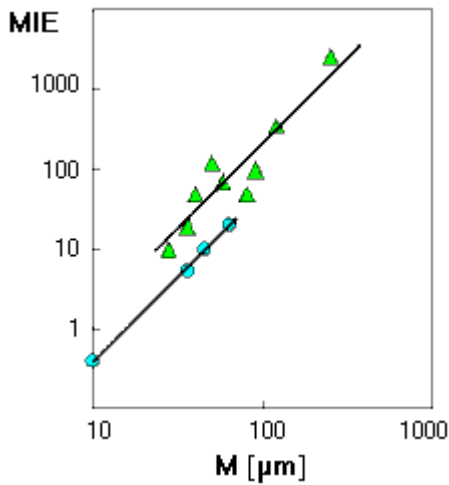

Fig. 1.2.5: Influence of the median value on the MIE

The particle size or the median value can have an appreciable influence on the minimum ignition energy. This energy limit value increases with the cube of the median value of a dust. The finer a dust, the easier it can be ignited.

This model calculation has only limited applicability. The following estimation is more conservative and in practice produces a better agreement with the experimental results:

$$MIE_2 = MIE_1 \cdot (M_2 / M_1)^{2.5}$$

Index 1: measured

Index 2: estimated

see MIKE-Software:

[Calculate / MIE - influence of Median](#)

1.2.6 Temperature

a) Estimation method according to Glarner

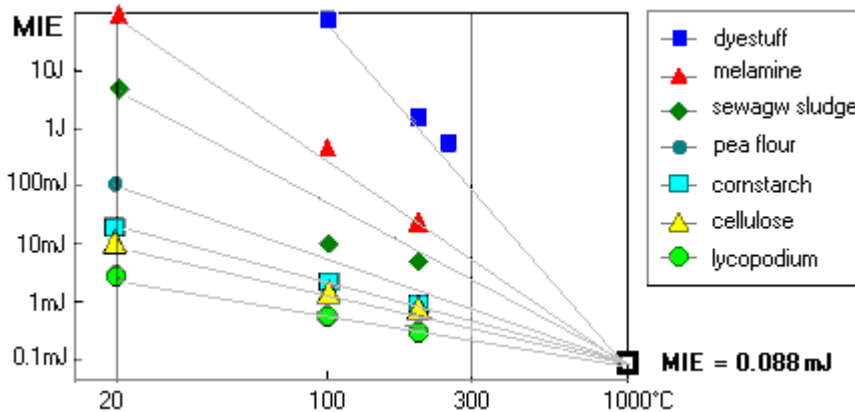

Fig. 1.2.6a: Influence of the temperature on the minimum ignition energy

The minimum ignition energy is also influenced by temperature. It is lowered by an increase in temperature to an extent which depends on the ignitability of the dust. A dust which is difficult to ignite shows a more pronounced effect than one which is readily ignited. As a result, a log-log plot comprises straight lines which meet at a point (1000°C; 0.088 mJ). If the minimum ignition energy of a dust is known at room temperature, a straight line connecting this point with the intersection point mentioned above thus describes the temperature dependence of the minimum ignition energy of the dust up to temperatures of 300°. The following equation can be used to estimate the MIE in a temperature range from 25 to 300°C:

$$MIE(T) = 10^{-4.056 + (1.873 - 0.624 \log T) \cdot (\log MIE(25^\circ C) + 4.056)}$$

T [°C], MIE [J]

see MIKE-Software: [Calculate / MIE - influence of Temperature](#)

**b) Measurements with MIKE4**

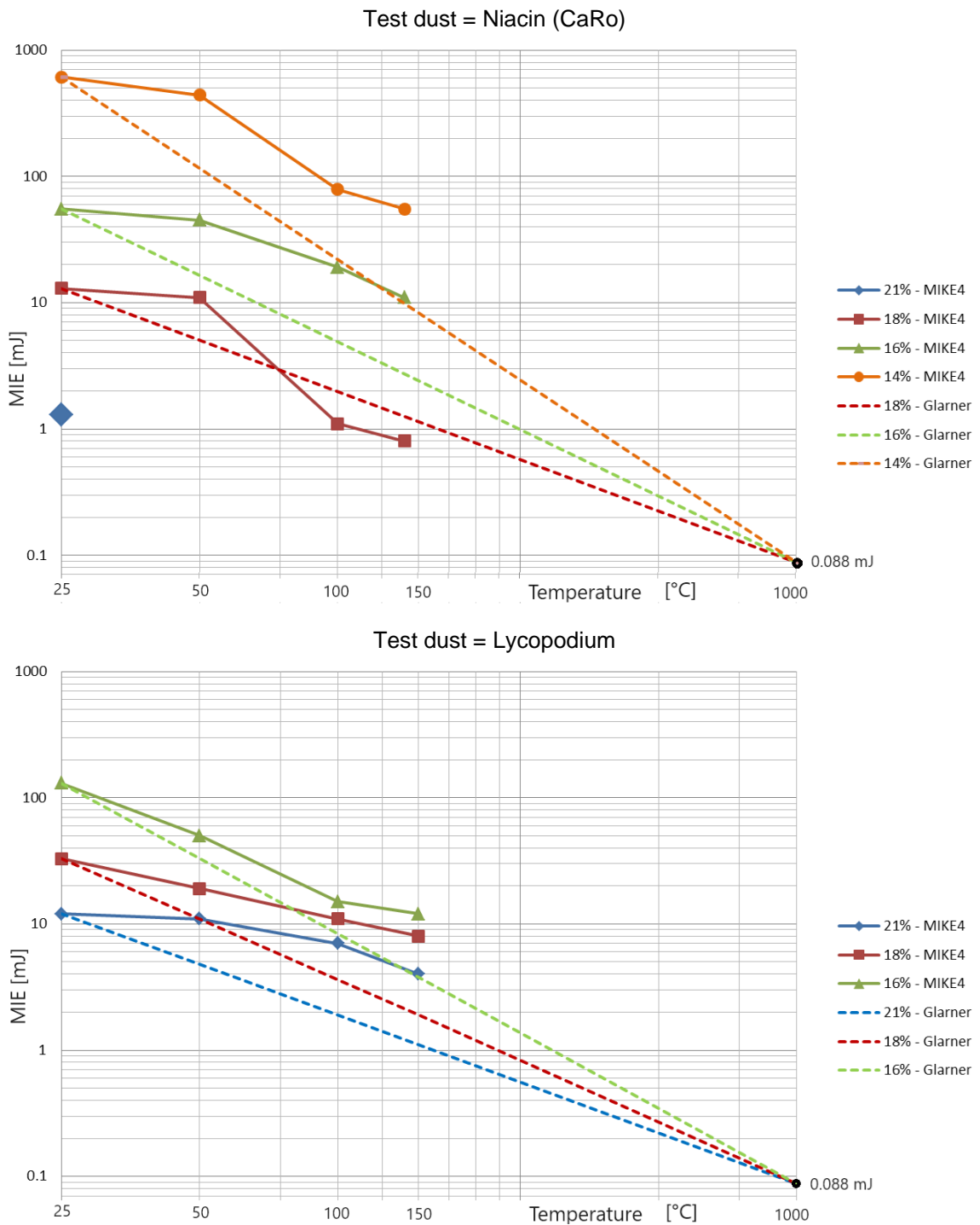

Fig. 1.2.6b: Temperature dependence of the MIE for different temperatures in a double logarithmic representation. The values calculated using the Glarner formula are shown as dashed curves.

Glarner's formula values can deviate considerably from the experimental results. In this respect, the simple determination of the MIE for elevated temperatures offers real added value when it comes to assessing explosion risks and developing protection concepts.

1.2.7 Oxygen concentration

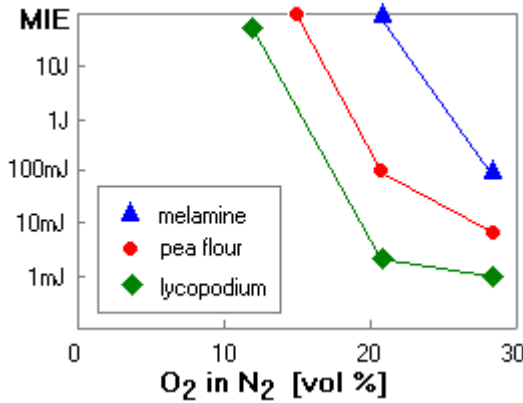
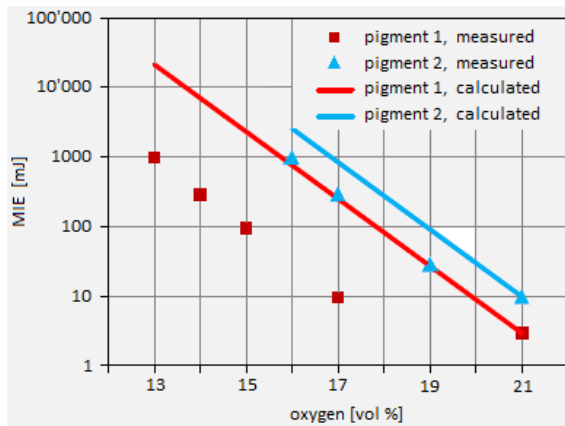

Fig. 1.2.7: Influence of the O<sub>2</sub> content

The O<sub>2</sub> content of the combustion air has a decisive influence on the minimum ignition energy (see adjacent plot). In a semi logarithmic plot, the MIE rises linearly, especially at low oxygen concentrations. This rapid decrease in the ignitability or increase in the MIE is primarily due to the addition of nitrogen, which has an inerting effect. With increasing oxygen concentration, on the other hand, the curves tend to flatten out reflecting a lowering of the rate of decrease of the minimum ignition energy.

a) Estimation method according to Glor and Schwenzfeuer



Studies on the behavior of the minimum ignition energy under oxygen-reduced atmospheres were published by Glor and Schwenzfeuer. They examined 22 different types of dust in a MIKE 3 and developed an estimation method for this purpose.

see MIKE-Software:

[Calculate / MIE - influence of Oxygen](#)

Fig. 1.2.7a

b) Measurements with MIKE4 (Niacin)

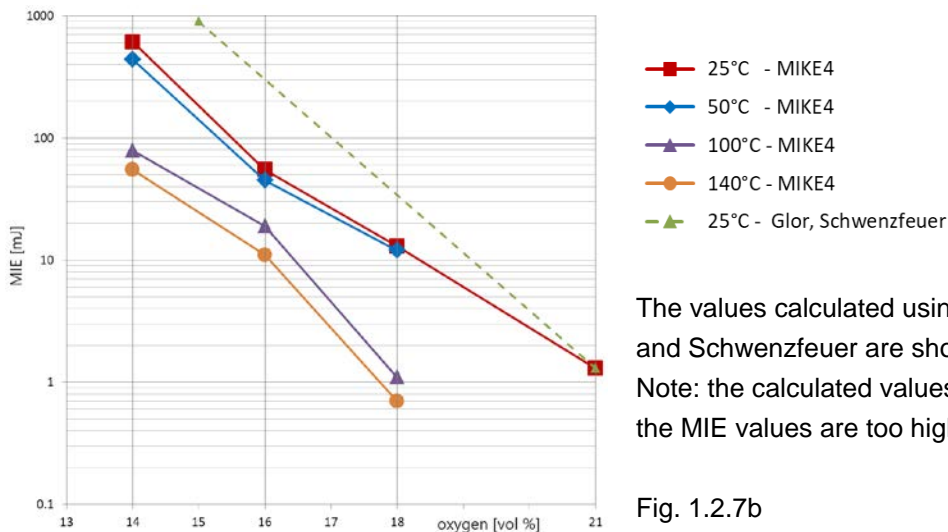

The values calculated using the formula from Glor and Schwenzfeuer are shown as a dashed curve. Note: the calculated values are not conservative, the MIE values are too high.

Fig. 1.2.7b

1.2.8 Addition of flammable gases

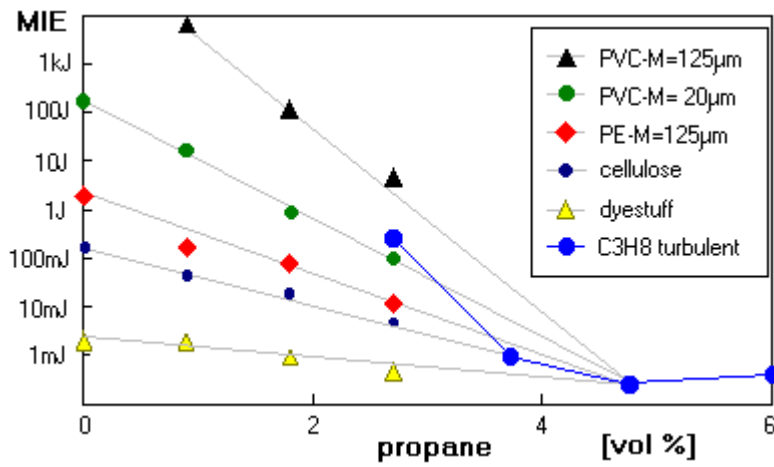

Fig. 1.2.8: Influence of the addition of flammable gas on the MIE

The addition of flammable gases (solvent vapours) to the combustion air lowers the minimum ignition energy of combustible dusts and this lowering is greater the more difficult they are to ignite. A semi logarithmic plot of the MIE against the added flammable gas content results in straight lines which meet at a point characteristic of the minimum ignition energy of the particular flammable gas.

see MIKE-Software: [Calculate / MIE - influence of Gas](#)

## 1.3 Test procedure

---

### 1.3.1 Standards

---

- a) EN13821: Determination of minimum ignition energy of dust/air mixtures
- b) ASTM E2019: Standard test method for Minimum Ignition Energy of a dust cloud in air
- c) ISO/IEC 80079-20-2: Material characteristics. Combustible dusts test methods

#### Dust concentration [mg]:

ASTM E2019, EN13821	300	600	900	1200	1500	1800	2400	3000
ISO/IEC 80079		750		1200		2000		3000

#### Ignition delay time $t_v$ [ms]:

ASTM E2019, EN13821	60	90	120	150	180
ISO/IEC 80079	60		120		180

The ISO/IEC 80079 standard is a subset of the ASTM E2019 and EN13821 standards with respect to dust concentration and ignition delay time.

#### Test procedures:

The test method according to ISO/IEC 80079 is a short form of the method according to ASTM E2019 and EN13821. Details, see: [1.3.4 Test procedure, example](#)

#### Calibration Round Robin CaRo:

In the test method according to ISO/IEC 80079, without consideration of the statistical energy  $E_s$ , the sole specification of the energy range ( $E_1$ ,  $E_2$ ) is not precise enough. A comparison of the results of different apparatus and their calibration is not possible.

#### Recommendation:

Tests according to ASTM E2019, EN13821 are valid for ISO/IEC 80079. But not vice versa! Therefore we recommend:

- a) Test according to ASTM E2019, EN13821, or
- b) Test according to ISO/IEC 80079, however with  $E_s$

#### History:

During the development of the minimum ignition energy apparatus "MIKE" in 1992 we have adopted the concentration levels from the 1m<sup>3</sup> container and the 20L sphere:

g / m <sup>3</sup>	250	500	750	1000	1250	1500	2000	2500
mg / 1.2L	300	600	900	1200	1500	1800	2400	3000

### 1.3.2 Test procedure, general

---

The energy just sufficient to ignite the dust under investigation is determined. This ignition energy is then successively halved with **variation** of the **dust concentration** and the **ignition delay time** (turbulence) in a series of tests until no ignition takes place in **at least 10** successive experiments. The minimum ignition energy MIE lies between the lowest energy value (E2) at which ignition occurred and the energy (E1) at which in at least 10 successive experiments no ignition was observed.

The energy range thus determined is called the minimum ignition energy of a combustible dust in admixture with air. However, for purposes of simplification often only the lower limit value (E1) is specified as the minimum ignition energy MIE.

$$E1 < MIE < E2$$



To assess the ignition hazard for dust/air mixtures due to operational spark discharges, especially electrostatic discharges, the minimum ignition energy MIE must be determined with a purely capacitive spark discharge (without inductance) by the method described above.

In the case of fuel gases, the inductance generally has no influence on the MIE. Highly flammable dusts often show the same behavior.

### 1.3.3 Statistic ignition energy (Es)

For the purpose of comparison between different apparatus, only one statistic MIE value (Es) instead of the energy range (E1, E2) should be used. This single value (Es) can be estimated by the use of the probability of ignition as follows:

$$Es = 10^{(\log E2 - I[E2] \cdot (\log E2 - \log E1) / ((NI+I)[E2] + 1))}$$

where is:  $I[E2]$  = number of tests with ignition at the energy E2.  
 $(NI+I)[E2]$  = total number of tests at the energy E2.

e.g.

IE \ mg	300	600	900	1200	1500		probability
E2 = 30 mJ	NI	I	I	I	NI	→	3 of 5
E1 = 10 mJ		NI	NI	NI			

$$Es = 10^{(\log E2 - 3 \cdot (\log E2 - \log E1) / (5 + 1))} = 17 \text{ mJ}$$

where is: **I** = ignition of dust  
**NI** = no ignition of dust in 10 trials

#### Accuracy of the Es - estimation

From the number of tests, the accuracy of Es can be estimated:

$$Smax = 10^{(\log Es + I[E2] \cdot (\log E2 - \log E1) / ((NI+I)[E2] + 1))}$$

$$Smin = 10^{(\log Es - I[E2] \cdot (\log E2 - \log E1) / ((NI+I)[E2] + 1))}$$

#### Examples of the accuracy of the Es - estimation

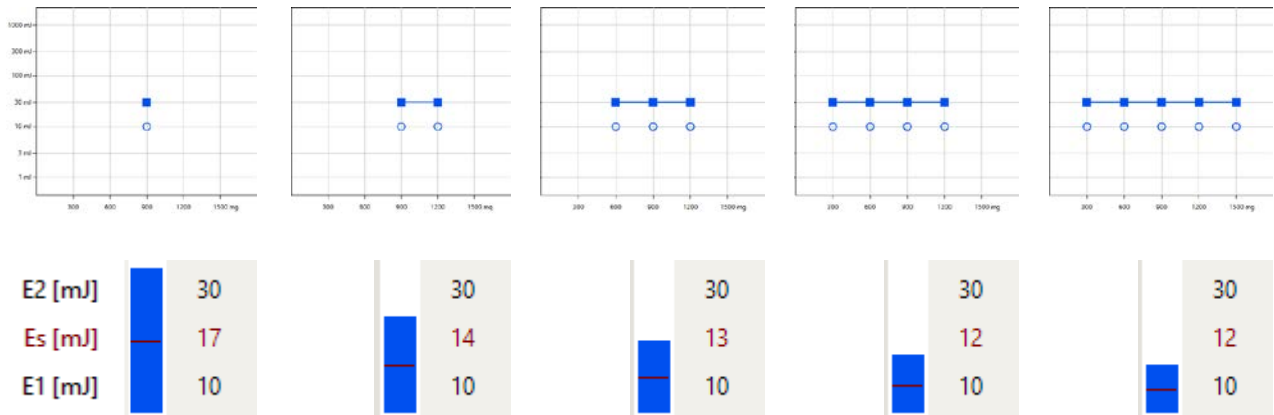

Examples for test procedure and statistic energy (Es)

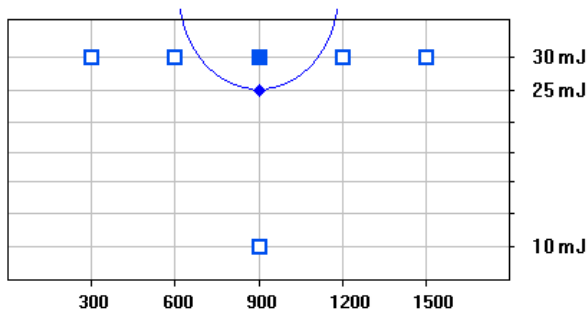

$E2 = 30\text{mJ} / E1 = 10\text{mJ}$   
 probability of ignition = 1 of 5  
 **$E_s = 25\text{mJ}$**

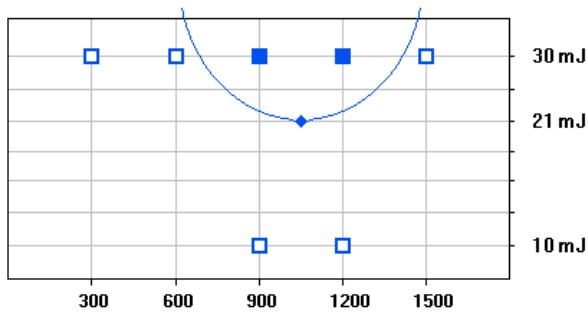

$E2 = 30\text{mJ} / E1 = 10\text{mJ}$   
 probability of ignition = 2 of 5  
 **$E_s = 21\text{mJ}$**

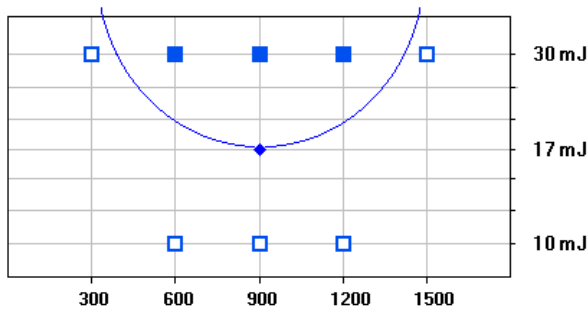

$E2 = 30\text{mJ} / E1 = 10\text{mJ}$   
 probability of ignition = 3 of 5  
 **$E_s = 17\text{mJ}$**

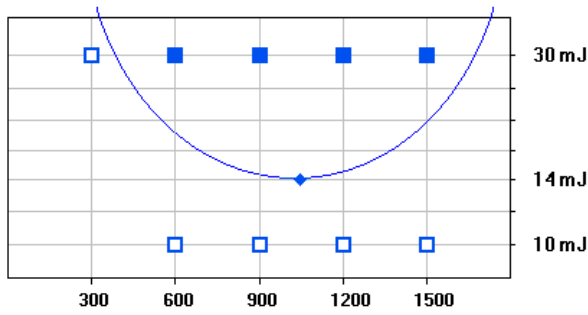

$E2 = 30\text{mJ} / E1 = 10\text{mJ}$   
 probability of ignition = 4 of 5  
 **$E_s = 14\text{mJ}$**

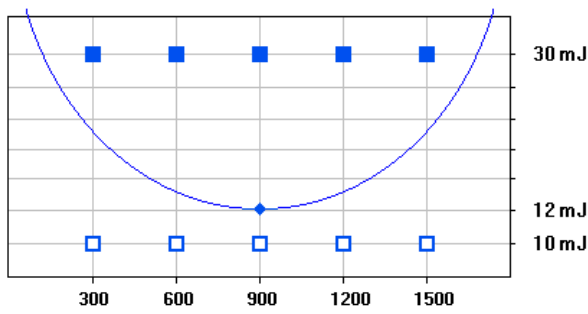

$E2 = 30\text{mJ} / E1 = 10\text{mJ}$   
 probability of ignition = 5 of 5  
 **$E_s = 12\text{mJ}$**

**Statistic energy (Es) under non-atmospheric test conditions**

For tests with elevated temperature and/or reduced oxygen content, the specification of the ignition probability  $E_s$  is **mandatory** for a meaningful presentation.

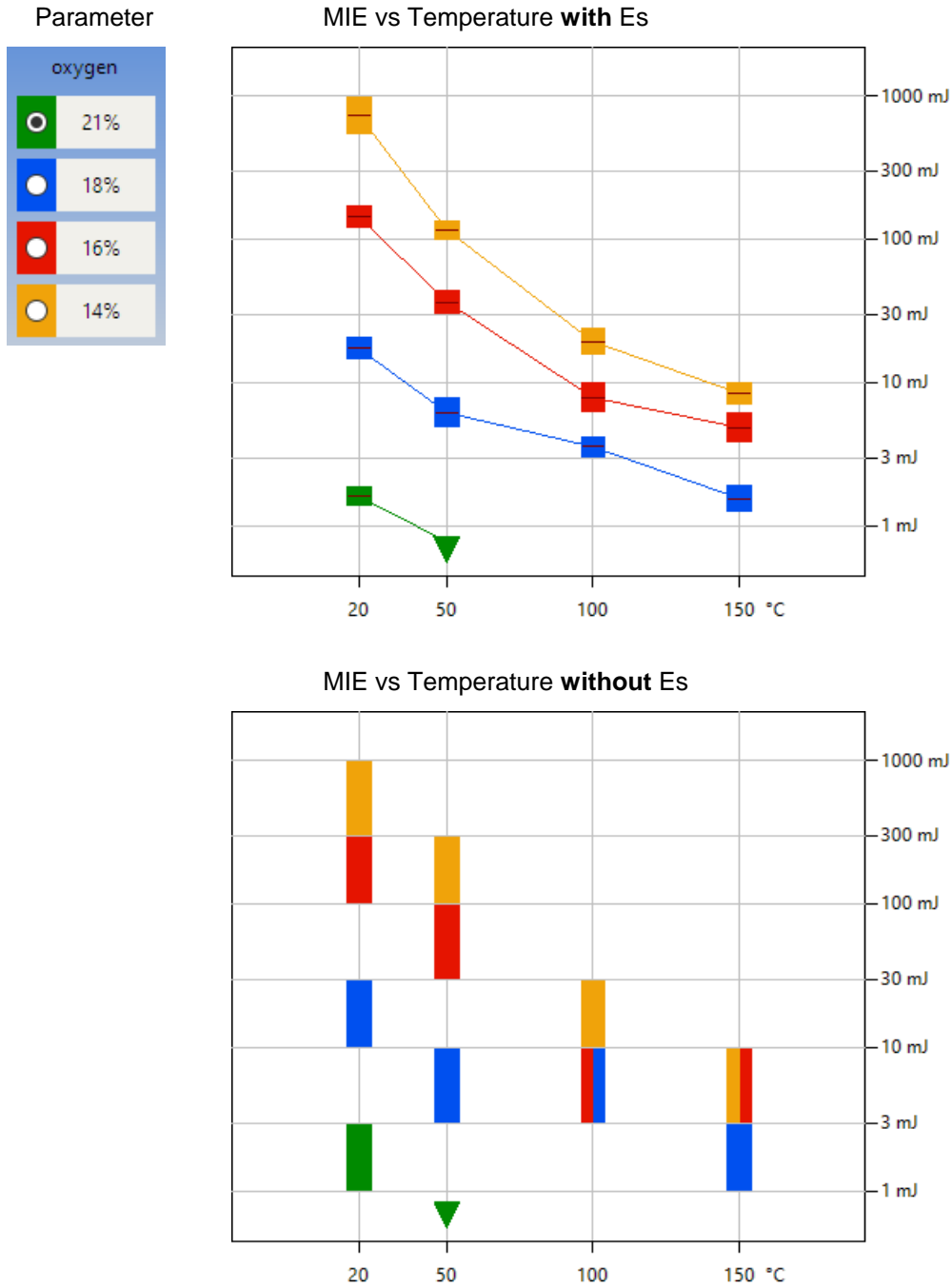

1.3.4 Test procedure, example

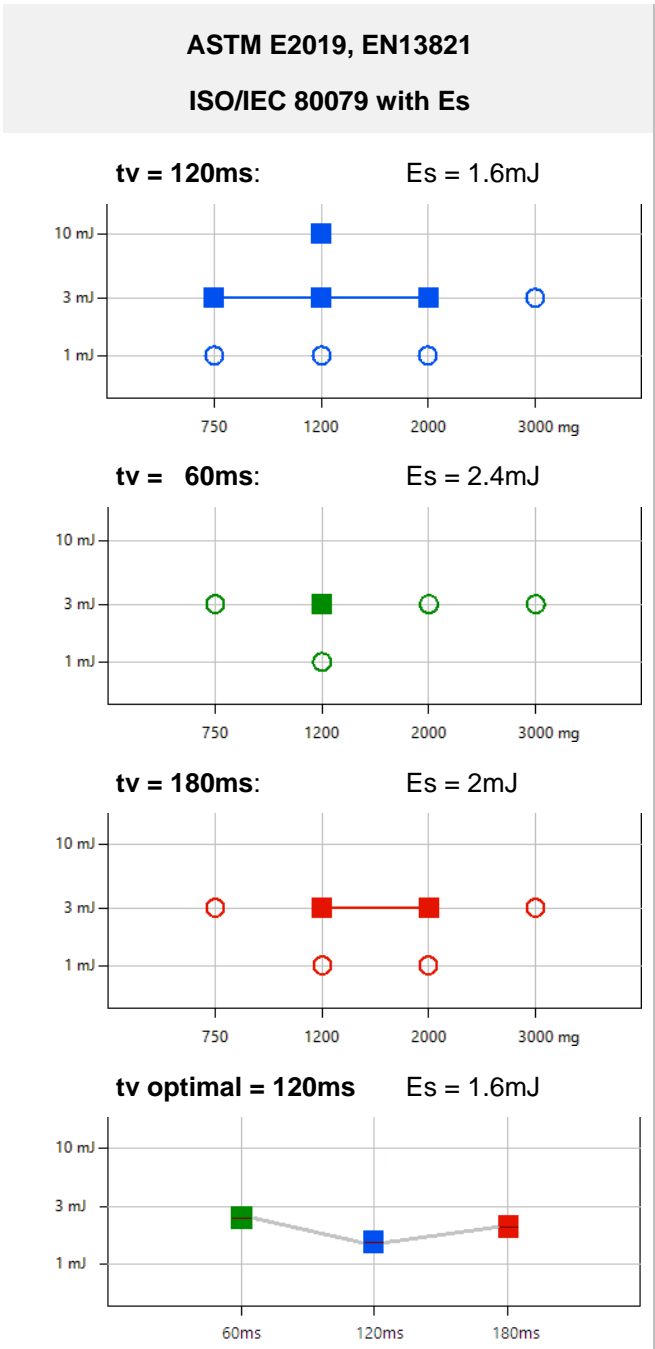

**Recommended test method.**

All standards are taken into account.  
The additional effort is small in relation to the more accurate result.

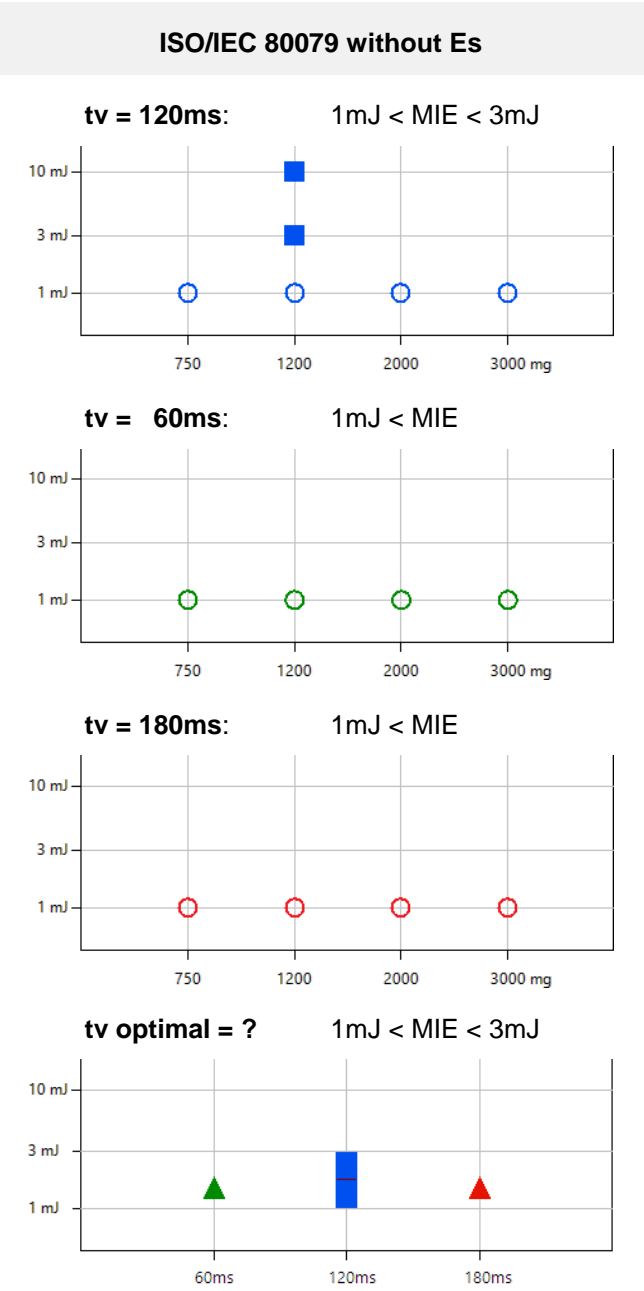

With this method, tv=60ms and tv=180ms only confirm that no lower MIE values are present. No statement can be made about the optimum ignition delay time tv.

## 1.4 Test apparatus MIKE 4

Based on the findings discussed in section 1.2, it has been internationally agreed that an apparatus for the determination of the minimum ignition energy of combustible dusts must fulfill the following minimum conditions:

- with an inductance in the discharge circuit:  $L = 1 \text{ mH} - 2 \text{ mH}$
- without an inductance in the discharge circuit:  $L \leq 0.025 \text{ mH}$
- electrode material: tungsten or stainless steel
- electrode diameter:  $d = 2 \text{ mm}$
- electrode spacing: at least 6 mm

A modified Hartmann tube made of glass with a volume of 1.2 liter is used as the explosion vessel. The dust dispersion system at the base of the tube is of the "mushroom-shaped" type around which the sample is loosely scattered. A blast of compressed air at 7 bar is used to disperse the dust in the glass cylinder where it is ignited by a spark between two electrodes.

Experiments have shown that dust/air mixtures can easily have MIE values less than 10 mJ. The measurement range of the MIKE 4 has thus been specially designed for the lower energy values. Due to pneumatically actuated high-voltage switches, the parasitic capacitances have been reduced by an order of magnitude.

A further improvement of the test equipment has been achieved by direct assembly of the capacitor discharge apparatus with the modified Hartmann tube. Long supply leads are thus avoided. The high-voltage unit and the explosion vessel are arranged in the same Faraday cage.

### 1.4.1 Schematic circuit diagram

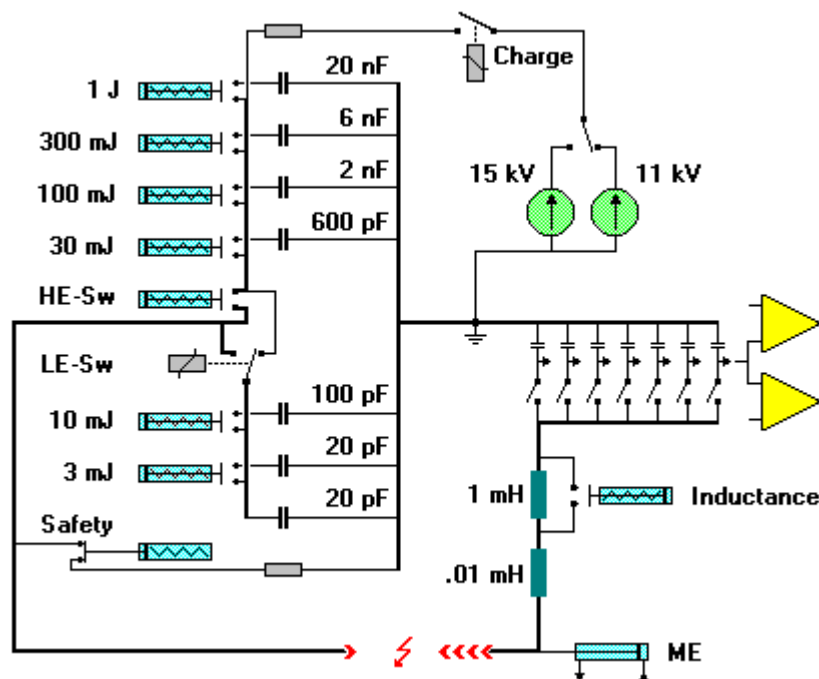

### 1.4.2 Discharge circuit for 1 mJ , 3 mJ - Triggering by high-voltage relay

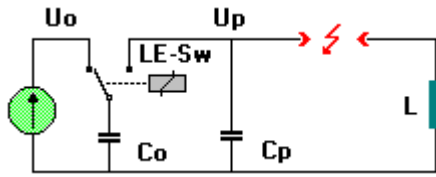

$U_o$  = charging voltage  
 $U_p$  = discharge voltage  
 $C_o$  = discharge capacitor  
 $C_p$  = parasitic capacitor (electrode holder)  
 $L$  = inductance (0.01mH / 1 mH)  
 LE-Sw = high-voltage relay

The discharge capacitor  $C_o$  is given the charge  $Q_o = U_o \cdot C_o$ . After switching of the relay "LE-Sw", the **charge** is retained, on the other hand the voltage  $U_o$  is lowered to  $U_p$  in accordance with the following equation:

$$U_p = U_o \cdot C_o / (C_o + C_p)$$

This results in a reduced spark **energy**  $E_p$  according to the MIE definition of:

$$E_p = 0.5 \cdot (C_o + C_p) \cdot U_p^2$$

### 1.4.3 Discharge circuit for 10 mJ ... 1 J - Triggering by moving electrode

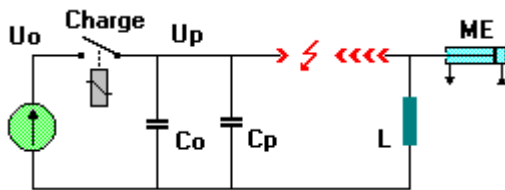

$U_o$  = charging voltage  
 $U_p$  = discharge voltage  
 $C_o$  = discharge capacitor  
 $C_p$  = parasitic capacitor  
 $L$  = inductance (0.01mH / 1 mH)  
 ME = moving electrode  
 Charge = charging relay

At the start, the moving ground electrode is in its home position. The electrode gap is then ca. 25 mm. Even with a charging voltage  $U_o = 15$  kV, the breakdown voltage is by no means reached. After opening the charging relay "Charge", the electrode is moved rapidly by the pneumatic system to the set minimum electrode gap of 6 mm. Sparkover occurs before the end position is reached. The spark energy  $E_p$  is calculated according to the MIE definition by the following equation:

$$U_p = U_o$$

$$E_p = 0.5 \cdot (C_o + C_p) \cdot U_p^2$$

### 1.4.4 Spark monitoring

In the determination of the minimum ignition energy, tests are performed for the absence of ignition. It is therefore essential that reliance can be placed on the correctness of the energy value of the discharge spark which just fails to ignite the dust/air mixture. The charge transferred by the spark is measured in every ignition experiment and a check is made for compliance with limit values.

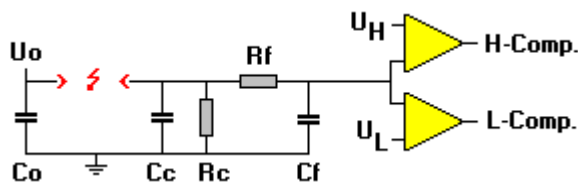

H-Comp = upper limit value

L-Comp = lower limit value

$C_o$  = discharge capacitor

$C_c$  = measuring capacitor

$R_c$  = leakage resistance

$C_f$ ,  $R_f$  = filter

The charge of the discharge capacitor  $C_o$  is transferred to the measuring capacitor  $C_c$ . The slowly increasing corona current occurring before the sparkover is also collected in the measuring capacitor  $C_o$ , but is discharged by resistor  $R_c$ . Only the charge transfer of the actual spark with its high transient current is recorded by this circuit.

The voltage characteristic across  $C_c$  corresponds, like the spark current, to a damped oscillation. The subsequent filter ( $C_f$ ,  $R_f$ ) now uses this to calculate the mean value for the spark monitoring. The peak value of this charge measurement must lie within the limits  $U_L$  and  $U_H$  to be recognized as a valid value.

### 1.4.5 Energy range

By definition, the MIE is represented by the energy stored in a capacitor. However, the charge of the capacitor and hence the spark energy is lowered not only by the corona current flowing before the sparkover; dirty insulators and possibly conductive dusts can also result in the dissipation of considerable charge.

Energy data which refer only to the initial charge of the capacitor are misleading. The actual energy value of the spark is **always less than** this theoretical maximum value and is thus unfortunately on the wrong side from the viewpoint of safety considerations. For example, a spark which just ignited a dust would actually have a lower energy than that specified!

Nominal	Maximum	Minimum	Triggering	Voltage
1 mJ	1.8 mJ	0.7 mJ	relay	15 kV
3 mJ	4 mJ	1.8 mJ	relay	15 kV
10 mJ	13 mJ	7 mJ	relay	15 kV
(10 mJ)	* 18 mJ	7 mJ	moving electrode	15 kV
30 mJ	40 mJ	18 mJ	moving electrode	11 kV
100 mJ	133 mJ	70 mJ	moving electrode	11 kV
300 mJ	400 mJ	230 mJ	moving electrode	11 kV
1 J	1.33 J	650 mJ	moving electrode	11 kV

Maximum = theoretical maximum value (worst case)

Minimum = lower limit of spark monitoring



**10 mJ** (ex-factory = relay)

\* relatively large corona losses must be anticipated.

Using Paschen's law and spherical electrodes, the temperature influence on the breakdown voltage at a 6mm electrode distance can be estimated:

19kV at 20°C and 13kV at 150°C

When triggered by "moving electrode", the corona losses at the electrode tip on the high-voltage side of the spark gap will increase at higher temperatures.

**1.4.6 Principle MIKE4**

It is important that the temperature and gas composition are homogeneous at the time of ignition.

For a high temperature homogeneity, the metal base and the Hartmann tube are regulated to the desired temperature.

The gas composition inside the Hartmann tube and in the container for dust raising must be identical. The gas mixture is blown in with a ring nozzle at the bottom of the Hartmann tube.

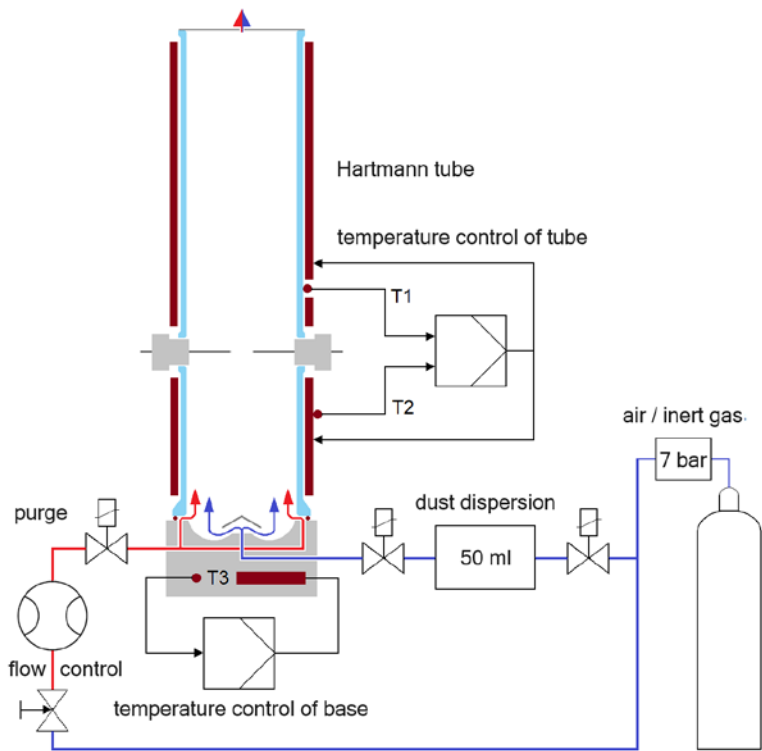

Fig. 1.4.6a Test device

**Temperature control**

The temperature of the metal base for the dust dispersion is easy to regulate. Achieving a homogeneous temperature distribution in the glass tube, on the other hand, is very complex. This cannot be achieved with a simple heating jacket around the glass tube. The MIKE4 therefore uses aluminum heating shells with a defined air gap to the glass tube. The surface temperature of the glass is measured and controlled in cascade to the heating shell temperatures. The front heating tray can be turned to the side for a quick change from the glass tube.

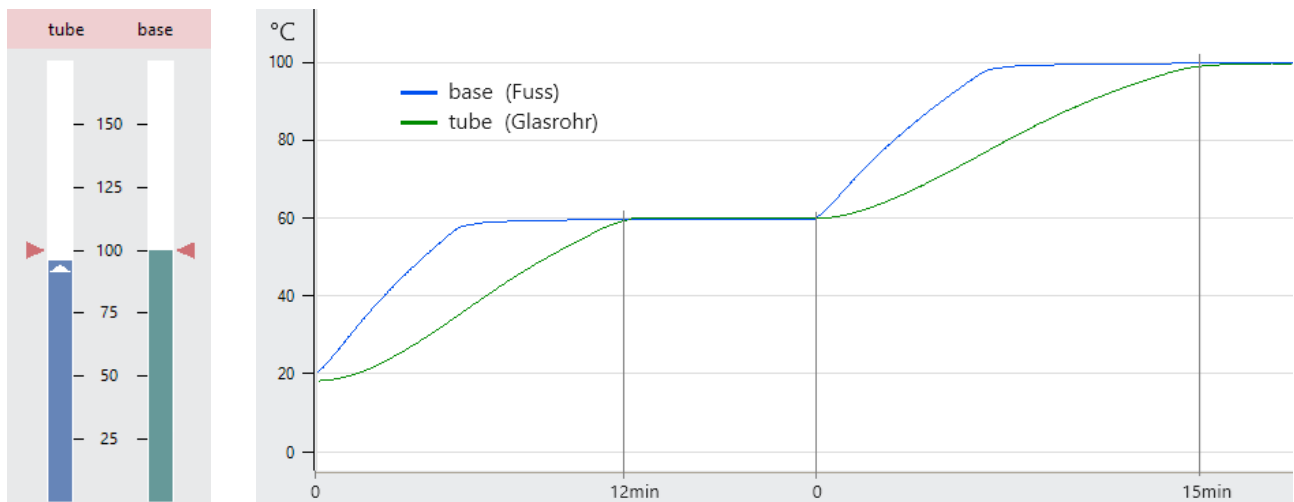

Fig. 1.4.6b: The current temperatures are displayed numerically and graphically (left). The MIE test can only be started when the temperatures are correct. The MIKE4 program contains temperature recording (right).

**Oxygen setting**

Gas mixtures with a defined composition from gas cylinders are used for tests under different oxygen concentrations. This allows the operators to concentrate on the MIE tests and not have to worry about the stability of the gas mixture. The gas mixture is injected with a ring nozzle at the bottom of the Hartmann tube (1.2L) and purged with a total of 3L from below. Measurements with an optical O<sub>2</sub> probe from Presens showed that with 5L/min and a total volume of 3L, the desired concentration is quickly achieved. In practice, the measuring delay of the probe does not have to be taken into account and flushing with a higher flow rate is permitted. Between tests without ignition, it is not necessary to flush with the full quantity of 3L. The MIKE4 calculates the refill quantity and thus saves gas mixture and time.

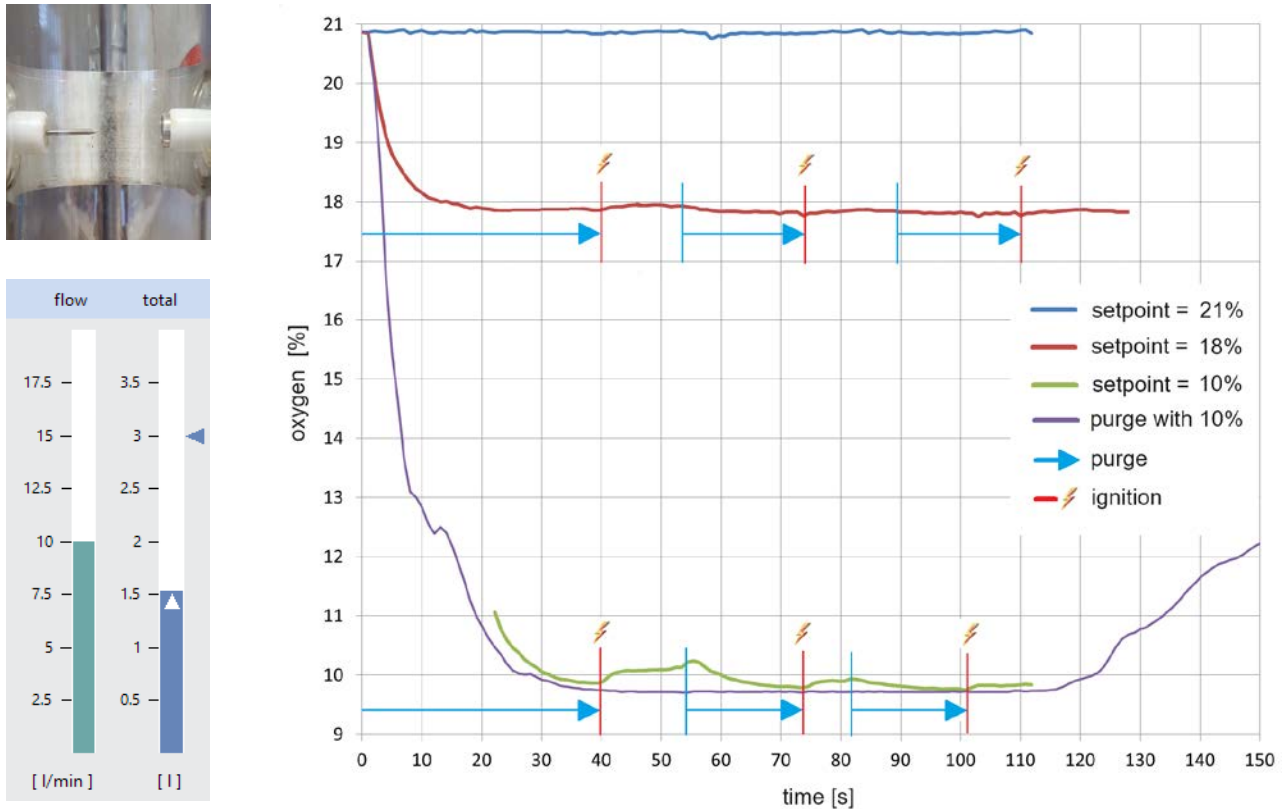
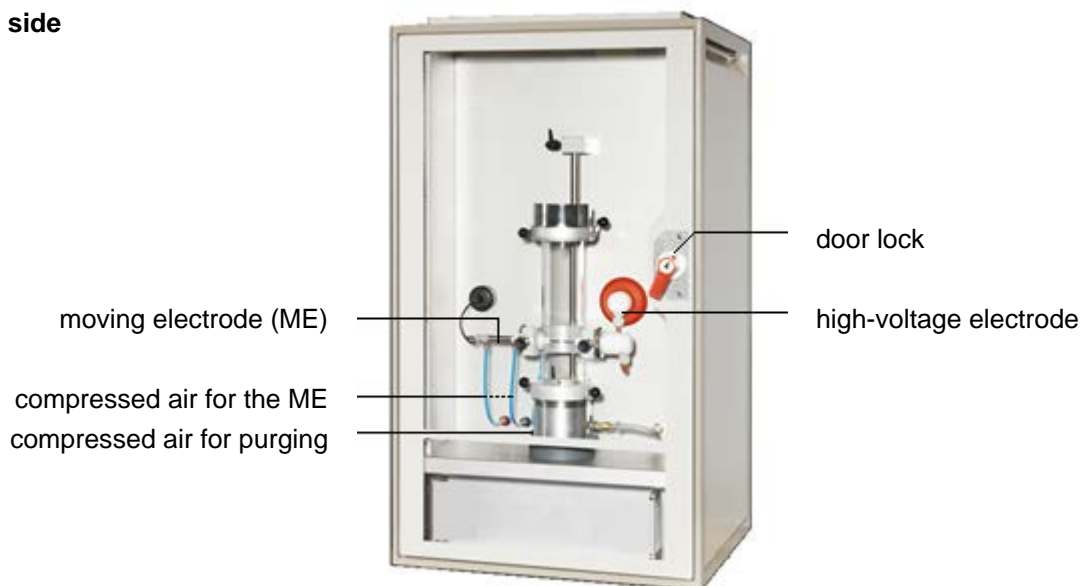

Fig. 1.4.6c: Presens probe (top left). In each case 3 tests without ignition of the dust (right).  
The current status of the gas filling is always displayed (bottom left).

## 2. Installation

### 2.1 Apparatus

#### Front side



#### Door lock with 3 positions:

1. Door open (electrode adjustment and cleaning):  
The high voltage is switched **off** and the keys are **enabled**.
2. Door closed (purging with air after test)  
The high voltage is switched **off** and the keys are **enabled**.
3. Door closed (MIKE is ready for a test)  
The high voltage is switched **on** and the keys are **disabled**.

#### Front panel:

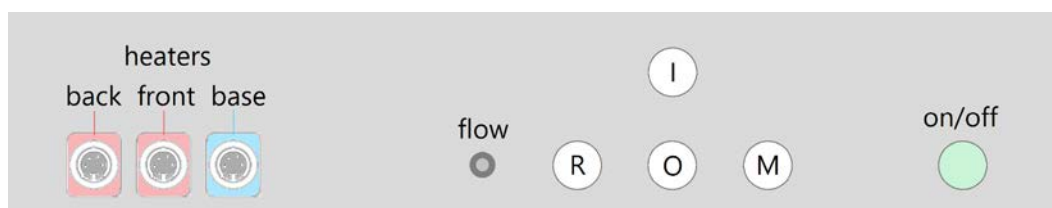

- I** Inlet valve, fill supply tank
- O** Outlet valve, empty supply tank
- M** Moving electrode (toggle function)
- R** Rinsing. Setting of the flow rate (typically 10 L/min)

**Connections (back side)**

compressed air connection  
(7 bar overpressure)

overpressure valve (10 bar)

air filter

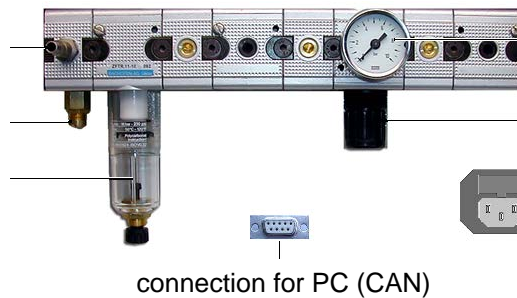

for pneumatic cylinders:

pressure indicator

pressure regulator (5 bar)

mains supply  
(100-240V / 50-60 Hz)

connection for PC (CAN)

**Compressed air supply:**

Compressed air is used to power the pneumatics and the dust dispersion.

Nominal value = **7 bar overpressure = 8 bar absolute.**

Only **normal compressor compressed air** may be used. With the use of synthetic compressed air MIE-values which are clearly different were obtained.

**Exhaust air:**

Fume hood for MIKE3 (option)  
outside diameter of the pipe = 90 mm,  
inside diameter = 75 mm

Air flow of ventilation approx. 500 m<sup>3</sup>/h

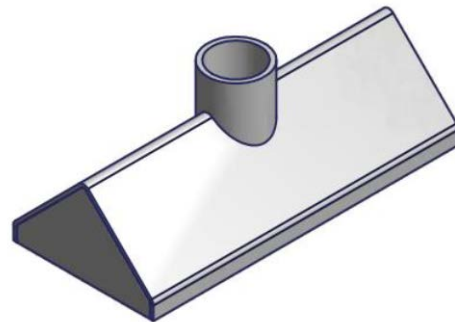
**Industrial Vacuum cleaner:**

These are necessary for the operation of the device, but are **not** supplied and must be provided by the user:

ATEX approved      Examples:      <https://howatec.ch/industriesauger-atex.html>  
<https://www.delfinindustriesauger.de>

**Safety instructions:**

Usually the MIKE is set up in a ventilated laboratory hood. When connecting the exhaust directly to the ventilation, the pressure of the blast as well as flames have to be considered.



For safety reasons, when manipulating with the electrodes, the plug of the high voltage electrode (on the right-hand side) must be **unplugged**.

The moving electrode (left-hand side) is always grounded and therefore safe.



Before making the electrical connections, please compare the information on the rating label with the data of your mains supply.

## 2.2 PC-Hardware

**Concept:** The CAN bus (Controller Area Network) is a serial bus system. The CAN bus originally developed by the Bosch company for the automobile industry in 1983, is internationally standardized and is now widely used in industry as a fieldbus under various designations and data protocols. This bus is characterized by its robustness. Even cable lengths of up to 100m between MIKE and CAN-USB adapters are possible.

Connection of a MIKE to one or more PC's:

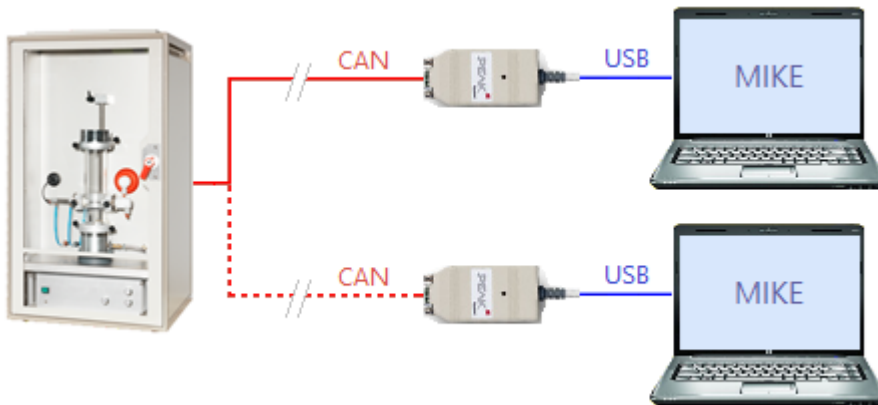

### Personal Computer (PC):

- Operating system Windows 7...11 (32/64-bit)
- USB port (USB 3.0, USB 2.0 or USB 1.1) on the computer
- Monitor resolution at least 1200 x 800

### Connection options MIKE - PC:

Cable DSUB 9 pin  
default



optical fiber  
(Option)



Ethernet  
(Option)



WLAN  
(Option)



## 2.3 PC-Software

Installation: Please run the following setup-file: **MIKE40\_setup.exe**  
 For the installation of the CAN driver, **Administrator rights** are required.

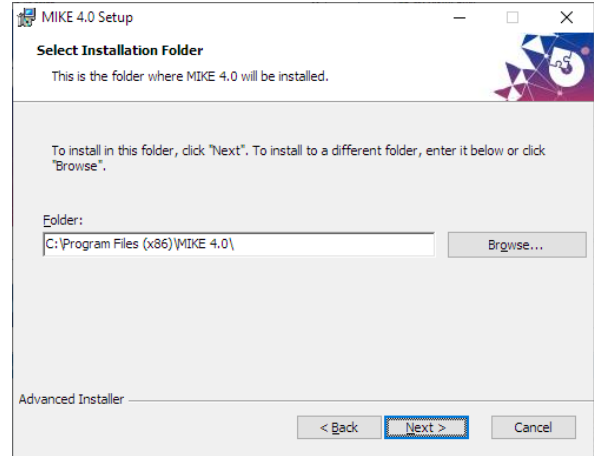
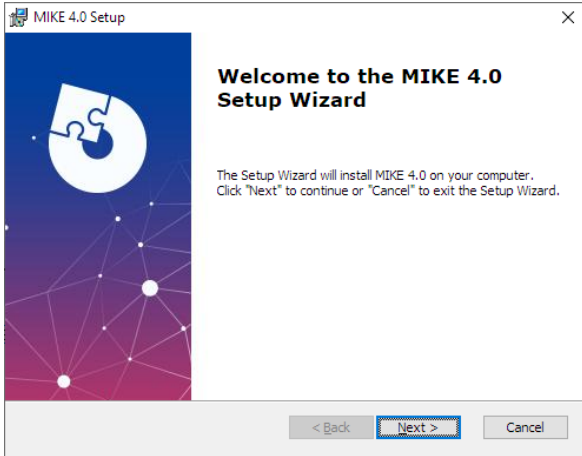

Start the MIKE-Software and follow the instructions:

### Setup 1

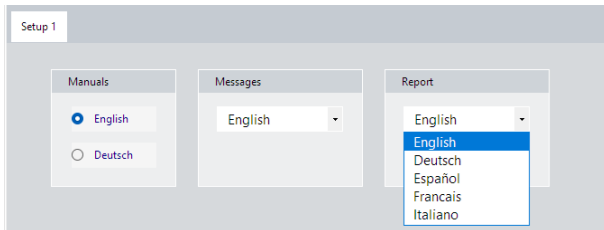

The program is always in English.  
 In addition to the predefined languages for messages to the operator and the test report, you can create your own translation files.  
 See: [4.2 Translations](#)

### Setup 2

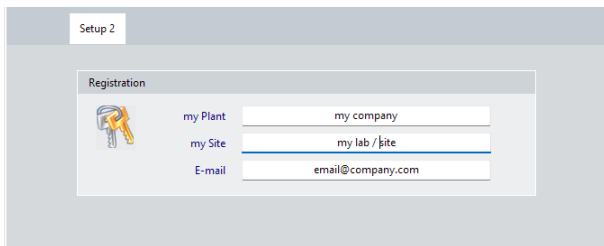

**my Plant** = Company name  
**my Site** = Testing laboratory for new files and the test report  
**E-Mail** for information only

### Setup 3: Administrator

The 1st administrator is defined here.  
Further users can be added in "Users".

**Signature** = Full name.

Will be inserted into the reports like this.

**Username** = a useful short form.

### MIKE-filename starts with ...

Automatically created file names begin with this, followed by the date the file was opened.

The letter following it distinguishes files created on the same day.

Example: Lab\_230224A.MIE these automatically created file names are only a suggestion.

Of course, you can enter your own file name (e.g. order number).

The extension of the file name is always "MIE" and is added automatically.

### MIKE

### Apparatus

MIKE 3 CAN or MIKE 4 CAN ?

*Apparatus is simulated:*

Most of the functions of the MIKE can also be simulated without an apparatus.

### Programm

**Automatic login:** Automatic program start after 60s.

**Master:** If several PCs are connected to the MIKE, only one may be the master.



Resetting the parameters to the default values.

### CAN-Driver

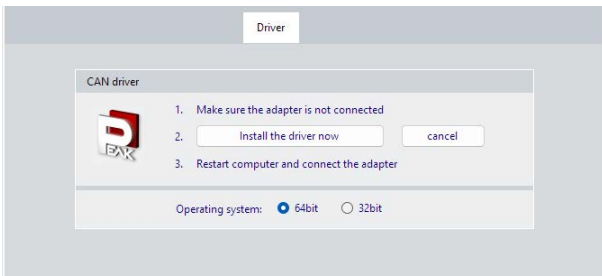

For the installation you need administrator rights. For the later use however no special rights are necessary.

Please do not use USB extension cables between CAN-USB adapter and PC. This does not comply with the USB standard and can lead to malfunctions.

#### Installation

- a) Do not connect the CAN adapter.
- b) Install the Peak driver.
- c) Connect CAN adapter to USB port.
- d) Windows notifies about new hardware.
- e) Restart the MIKE program.

#### Info

There is a red LED on the CAN-USB adapter:

- Constantly lit: connected to Windows
- Slow blinking: connected to MIKE
- Fast blinking: data is being transferred

### CAN-ID

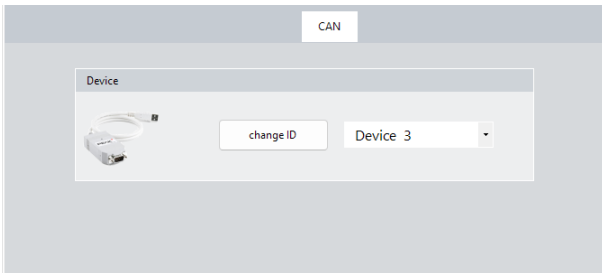

If several CAN adapters are connected to your PC, they must be uniquely identified.

For a new adapter, this number is usually 255 (0xFF). You can change this easily: [change ID](#)

### Users

Users					
no	username	signature	authorization	enabled	status
1	JS	John Smith	Administrator	✓	new
2	SE	Serge Egger	Service	✓	new
3	SU	Susan Unger	Supervisor	✓	new
4	OP	Olga Prost	Operator	✓	new
5					
6					
7					
8					
9					

The 1st administrator is defined at [Setup 3](#). Further users can be added here:

- "Administrator" for the management of users.
- "Service" for calibration and maintenance.
- "Supervisor" for process monitoring.
- "Operator" for all other users.

### Rights

Rights					
no	can do ...	Administrator	Service	Supervisor	Operator
1	Neue Tests	✓	✓	✓	✓
2	Dateimanager (neu, speichern)	✓	✓	✓	✓
3	Tabellenänderung	✓	✓	✓	✓
4	Testbedingungen	✓	✓	✓	
5	Software-Update	✓	✓		
6	System – Einstellungen	✓			

The rights of the 4 user groups can be defined here by the administrator.

### 3. Operation

#### 3.1 Program start



After starting the program, select the desired user.

See: 2.3 PC software

New users first need to enter here their own password.

username	signature	authorization	status
CC	Ch. Cesana	Administrator	active
SE	Clint Eastwood	Service	active
SU	Terence Hill	Supervisor	new
OP	Bud Spencer	Operator	new

Password  Login

#### 3.2 Main screen

##### 3.2.1 Info

The screenshot shows the MIKE 4 software interface. At the top, there is a menu bar with 'File', 'Calculate', 'Check', 'System', and 'Help'. Below the menu is a tabbed interface with 'Info', 'Atmospheric', 'Temperature', 'Oxygen', 'Series', and 'Audit'. The 'Info' tab is active, displaying a form for 'Niacin CaRo18' with fields for product, order, customer, reason, median, preparation, and comment. Below this, there are fields for plant, site, filename, created date, apparatus, and imported file. A central data table is visible, showing columns for T [°C], O2 [%], E1 [mJ], Es [mJ], E2 [mJ], tv [ms], and Induct. The table contains 18 rows of data. At the bottom of the interface, there is a status bar with user information (CC, Administrator, Master, CAN 3) and various parameters (ambient, tube 27.9°C, base 27.5°C, 6.8 bar) and a value 2502.

- 1
- 2
- 3
- 4
- 5
- 6
- 7
- 8
- 9

- 1. The actual user
- 2. Access rights of the user
- 3. Access rights to the MIKE
- 4. CAN-interface
- 5. Temperature - Set point
- 6. Temperature - Glass tube
- 7. Temperature - Base
- 8. Dust dispersion pressure
- 9. Software: version, year, week

### 3.2.2 Atmospheric

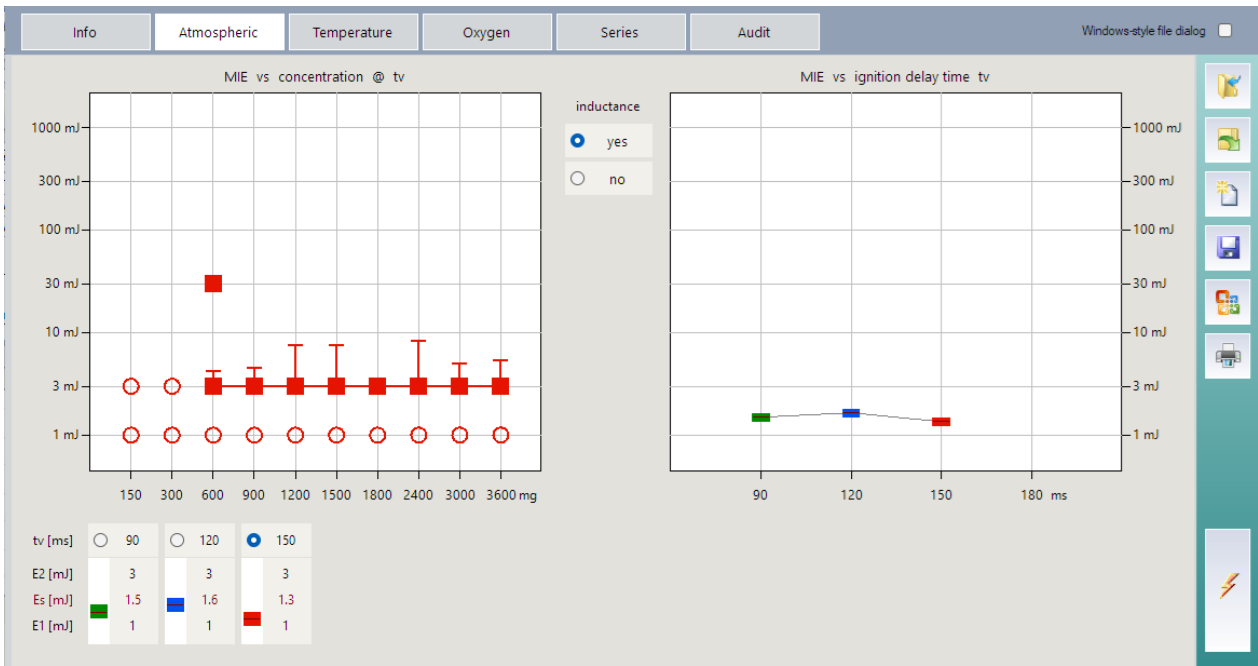

MIE vs dust concentration  
parameter = ignition delay time tv

MIE vs ignition delay time tv

### 3.2.3 Temperature

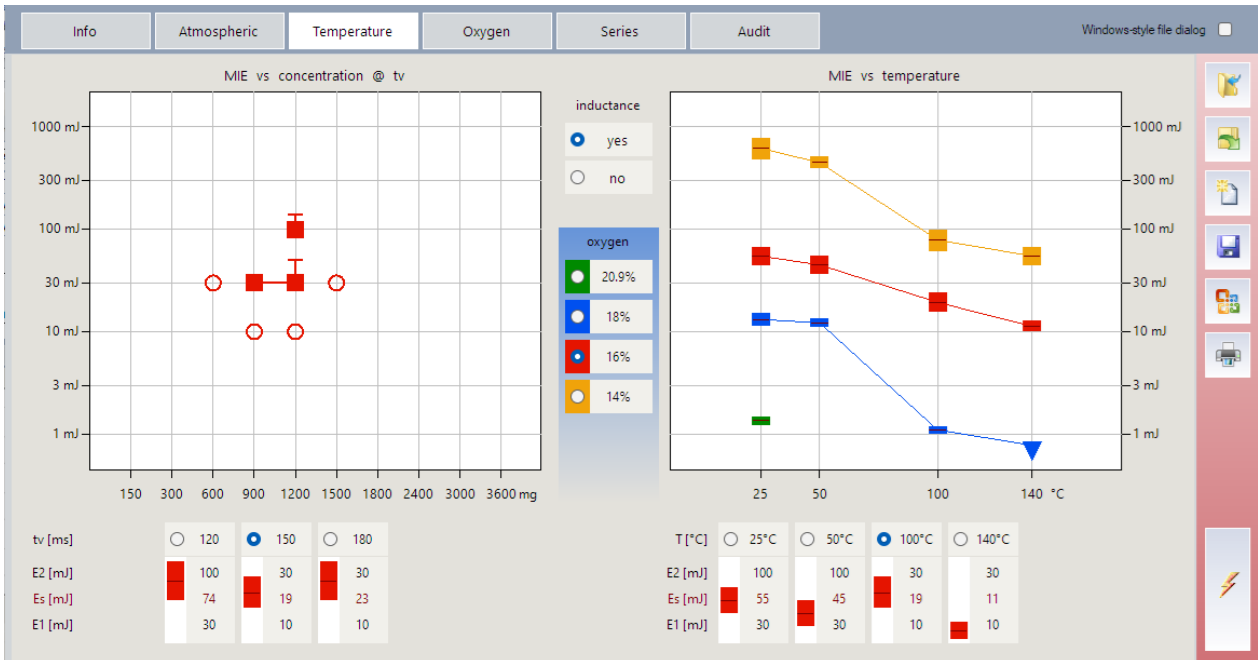

MIE vs dust concentration  
Parameter = Ignition delay time tv

MIE vs Temperature  
Parameter = Oxygen content

### 3.2.4 Oxygen content

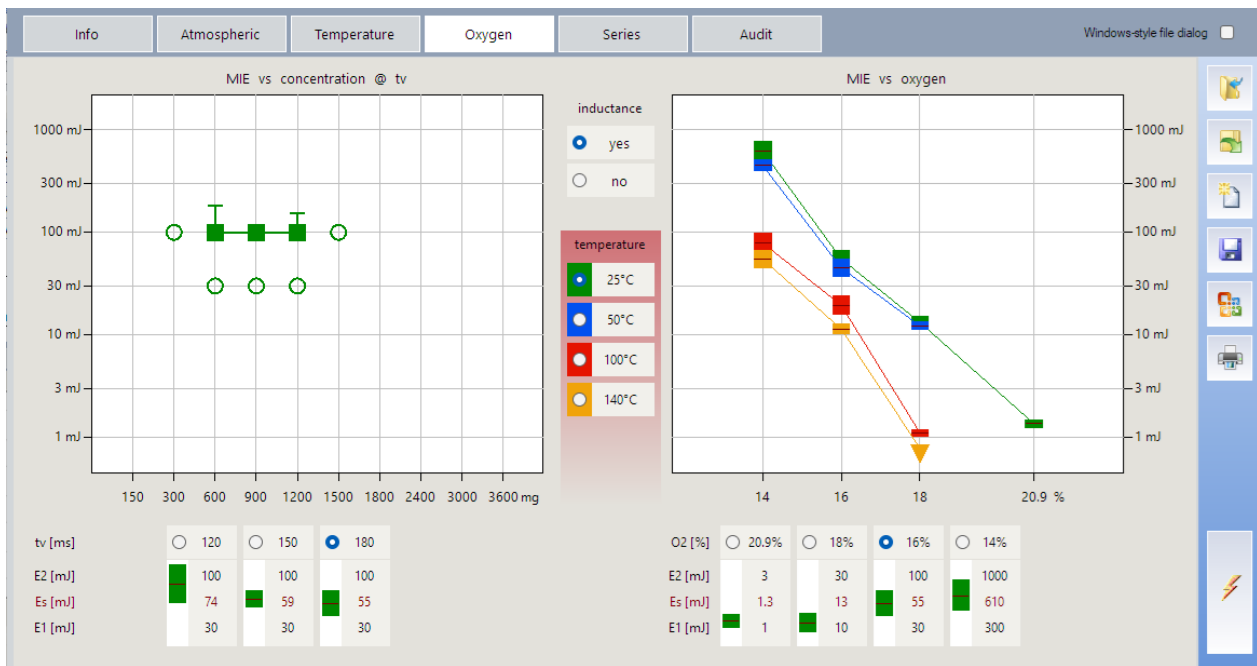

MIE vs dust concentration  
 Parameter = Ignition delay time tv

MIE vs Oxygen content  
 Parameter = Temperature

### 3.3 MIKE - Files



#### New Product, new File

At the start of a test with new dust, a new file is opened. The file name is automatically allocated by the program (**A**) or given by you (**B**):

- A:** Automatic generated filenames starts always with the identity (see: 2.3 PC-Software, 3. Administrator), followed by the date when the file is opened. The subsequent letter distinguishes files which are generated on the same day.

example 1: Identität\_201122A.MIE

example 2: Identität\_201122B.MIE (generated on the same day as example 1)

- B:** example 3: my\_product.MIE (maximum length of filename = 126 characters)



#### Existing product, open file

An index of MIKE-files is shown with filename and product. You can sort the fields ascending or descending by a click on the corresponding (*filename, date, product*).

Open Mike-file		
E:\PROGNET_C\MIKE4\bin\MIKEDAT\		
filename	date	product
Demo_Atmospheric.MIE	18.08.2020	Niacin CaRo18
Demo_Temperature_Oxygen.MIE	17.08.2020	Niacin CaRo18



#### Save files

All data is always backed up **automatically**. If necessary, however, you can save the entire recording in a separate file with a new file name.



#### Copy files

An easy-to-use file manager for copying MIKE files is built in.  
Only MIKE files are displayed.

Windows-style file dialog

File selection in Windows style or with product display.

3.3.1 Access rights



In the laboratory, the software must be suitable for the equipment.  
 In the office, we recommend the MIKE 4.0 software, as it can read all older files, is much easier to use and more flexible in the test report.

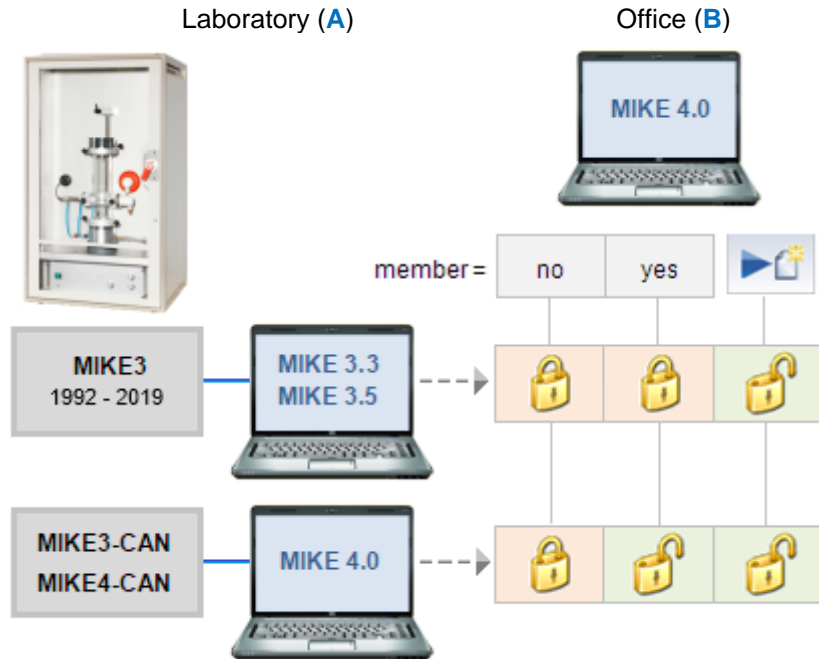

When transferring files to other computers, e.g. from the laboratory (A) to the office (B), the users must be taken into account. The user (B) must be a **member** in user list of the laboratory (A). Otherwise the data must be imported.



**locked**

All manipulation of the data is blocked, except for viewing and printing.



**freely accessible**

You can edit the tables and add comments.



**MIKE3.3** - files do not yet have user administration and the file format is different. Therefore, the MIKE3.3 file must be saved in MIKE4.0 format for manipulations.

A new file name is generated: e.g. M030618A.SIB becomes M030618A\_3.MIE

Locked **MIKE3.5** - files must be imported for free access.

A new file name is generated: e.g. CaRo24.MIE becomes CaRo24\_3.MIE

Locked **MIKE4.0** - files must be imported for free access.

A new file name is generated: e.g. CaRo25.MIE becomes CaRo25\_4.MIE

For the user management, the import of data is registered in the audit:



no	date	time	cause	event	username	signature
95	27.03.2025	10:19	OP1	MIKE data imported (3.5)	JS	John Smith
					OP1	my Operator 1

### 3.4 Test procedure

---

#### 3.4.1 Sample preparation

---

The lowest values of the MIE of a product are obtained if the sample is tested when it is dry and containing a fine particle size fraction. The product preparation is thus immensely important.

The product should be carefully dried by one of the following methods:

- a) 24 h at 50°C under vacuum
- b) 24 h at 75°C under atmospheric pressure



The sample must be prepared so that the median value **M** is less than **63 µm**.

Due to the big influence of the particle size distribution on the MIE (see 1.2.3) the particle size distribution and the corresponding median value M must be measured and indicated in the report.

In justified exceptional cases the dust can also be tested as supplied.

#### 3.4.2 Requirements

---



##### **Electrode spacing = 6 mm**

Move the moving electrode using the „ME“ (moving electrode) key to the working position and adjust the gap between the moving and fixed electrode with the gauge supplied to 6 mm (screw adjustment of the fixed electrode).

International guidelines require an electrode gap of at least 6 mm.



##### **Dispersion pressure Pz = 7 bar (over pressure)**

The compressed air for dispersion of the dust and for the pneumatic system of the moving electrode must be set to 7 bar +/- 0.5 bar (manometer gauge = 7 bar).

#### 3.4.3 General test procedure

---

1. Start with a dust sample weight of 900mg (1200mg), an ignition delay time of 120ms and an ignition energy with a high ignition probability e.g. 100mJ.
2. Lower the energy until the dust no longer ignites in **10** successive tests.
3. At energy (**E2**), where an **ignition** occurs, continue testing with higher and lower dust concentrations.
4. All dust concentrations with an ignition at an energy (E2) must be confirmed by „**10 no ignitions**“ at an energy level (E1).



The entire procedure must then be repeated with different ignition delay times (in steps of 30ms) to find the actual lowest ignition energy at the optimum ignition delay time for the dust under test.



The entire test sequence is performed twice for every dust: Once **with** an inductance, where the spark is protracted, and once **without** an inductance - if requested.

### 3.4.4 General test execution



Open the window „Next Series“ by a click on this button or by pressing the „enter“-key.

NI max	tv set [ms]	conc. [mg]	energy	oxygen [%]	temp. [°C]
10	120	900	30 mJ	21	< 30

tests tv eff  no dust

? New Series ?

1. Enter the parameters of the new series on the screen.  
(Concentrations that have already been tested are highlighted in gray)
2. Take out the base and distribute the dust evenly around the mushroom-shaped nozzle  
Alternative: Add the dust from above to the tube. However, it is necessary to ensure that the amount of dust adhering to the electrodes is kept at a minimum.
3. Close the door and lock.
4. Start the series by clicking or pressing the „Enter“ key.
5. Observe the test.

tests tv eff

1 121

yes no

? Dust ignited ?

#### The dust was ignited:

6. Inform the computer of this by clicking „Yes“ or press the „Y“-key.
7. Release the door lock of the MIKE (this enables the keys for manual operation).
8. Roughly pre-clean the apparatus with compressed air through repeated, alternate opening of the inlet (I) and outlet (O) valves.
9. Open the door. Vacuum off the residues and clean the tube, the mushroom-shaped nozzle and the electrodes.

### The dust was not ignited:

---

6. Start the next test by clicking „No“ or pressing the „Enter“ key. The remaining dust is again dispersed and possibly ignited.



If the dust was not ignited a little dust has escaped through the hinged cover. In addition some dust adheres to the tube wall and the electrodes. As a result, the dust concentration gradually decreases. Experience has shown that with the same dust filling up to 4 tests can be done. The dust concentration in the MIKE-apparatus is just a relative parameter. We recommend, independent from the dust concentration, to proceed as follows:

3 tests (see 6.)  
 - cleaning (see 7. - 9.)  
 - fresh dust sample (see 2.)

3 tests (see 6.)  
 - cleaning (see 7. - 9.)  
 - fresh dust sample (see 2.)

4 tests (see 6.)

### Error messages:

---

#### Charge too low ? No spark ?

No sparkover occurred or the spark energy was too low. Clean the electrodes and insulators thoroughly and check the electrode gap if need be. Electrostatic charged dust can also influence the sparkover with its electric field . The sparkover occurs too late and the energy is too low due to the corona current . Clean the glass tube with water (this lowers the resistance of the surface). Then start the next test with a new dust filling.

#### Deviation of $t_v > 10$ ms

In triggering by the moving electrode, the mechanical system is probably dirty and stuck. Clean the piston rods and apply a little oil if necessary. Actuate the piston several times with the „ME“ key.

In triggering by the high-voltage relay, electrostatic charges are probably the cause of the delayed sparkover. Clean the glass tube with **water** (this lowers the resistance of the surface). Then start the next test with a new dust filling.

### Checking the sparkover:

---

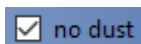

To test the sparkover, you can interrupt the normal test procedure at any time by selecting „spark only“. The dust is then not dispersed - and need not be vacuumed off. Select „with dust“ to return to the normal test procedure.

### 3.4.5 Graphics

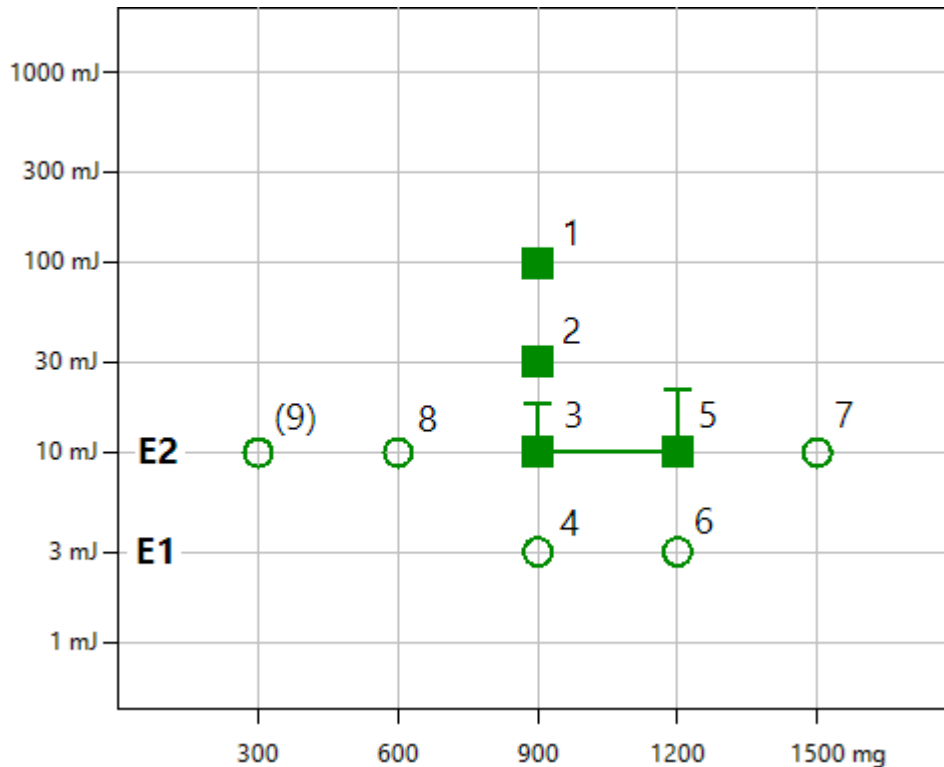

The series **with ignition** of the dust (**solid squares**) and the series **without ignition** of the dust (**outline circles**) are displayed each time. The vertical pointers (T-shaped) indicate how many single tests were necessary until the dust was ignited (low ignition probability). If the dust was ignited in the first test (high ignition probability), no vertical pointer appears.

#### Example for the test procedure

- 1 Start with a dust sample weight of 900 mg, an ignition delay time of 120 ms and an ignition energy with a high ignition probability e.g. 100mJ.
  - 2,3,4 Lower the energy until the dust no longer ignites in **10** successive tests.
  - 5,7,8 At energy (**E2**), where an **ignition** occurs, continue testing with higher and lower dust concentrations.
  - 4,6 All dust concentrations with an ignition at an energy (E2) must be confirmed by „**10 no ignitions**“ at an energy level (E1).
  - <9> For the calibration, **at least 5** different dust concentrations are required to calculate the ignition probability.
-  The entire procedure must then be repeated with different ignition delay times (in steps of 30ms) to find the actual lowest ignition energy at the optimum ignition delay time for the dust under test.

### 3.4.6 Entering the parameters

---

A list of useful values is stored for all parameters. This list can be easily supplemented. Excluded are the values for the ignition energy, because these are determined by the apparatus.

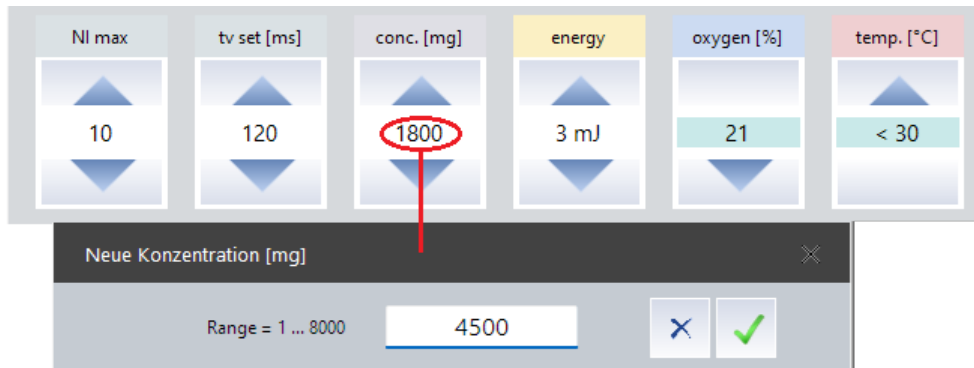

Resetting of the lists to the given default values.

### 3.5 Test condition

#### 3.5.1 Atmospheric



**Oxygen = 21%**

**Temperature <math>< 30^{\circ}\text{C}</math>** (Maximum ambient temperature)



The limit value of  $30^{\circ}\text{C}$  can be adapted to your ambient conditions.

See: [3.5.4 Adjustment of settings](#)





If the base- and/or the tube-heaters are not connected, the temperature is automatically switched to the ambient temperature.

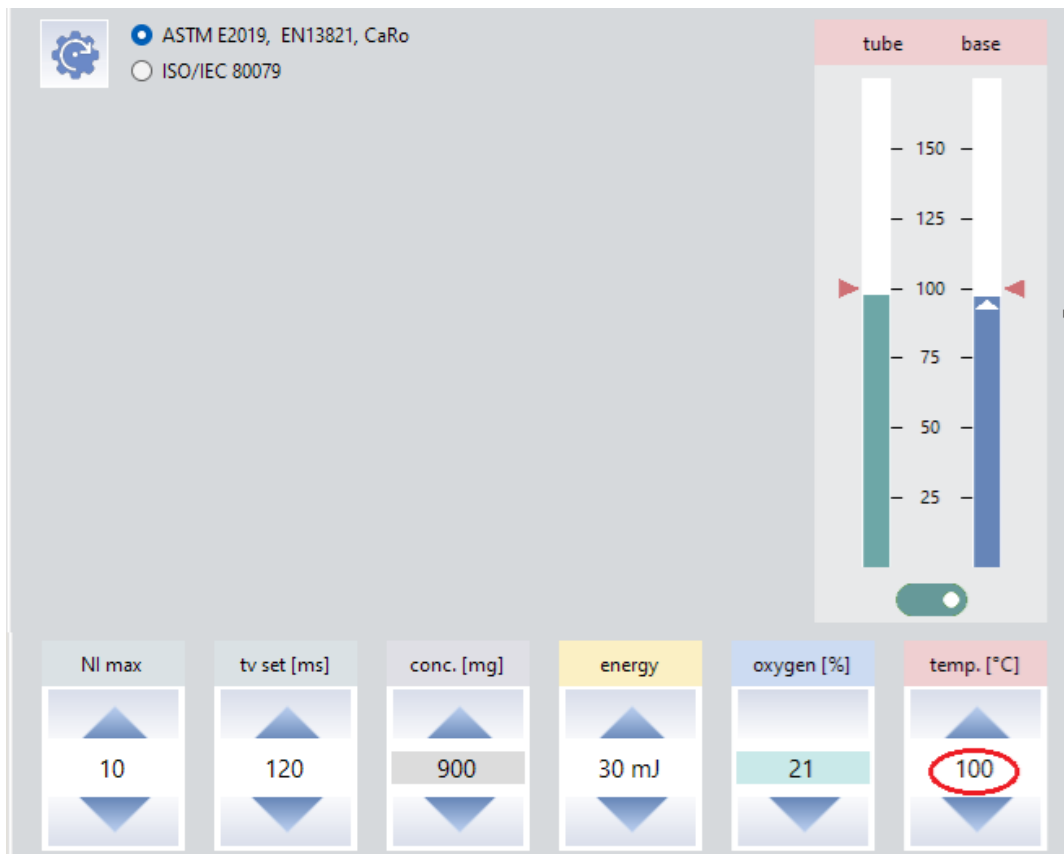

### 3.5.2 Temperature



 The temperature controller must be switched on explicitly.

 Temperature is still too high, but falling.

 Temperature is OK.

 Temperature is still too low, but rising.

### 3.5.3 Oxygen



Before dust dispersion and ignition sparks, the glass tube is filled with the gas mixture from below. The ambient air is displaced and flushed out. According to experience, the desired gas mixture is reached in the glass tube after a filling of 2L (total) and the test is then started automatically.

The gas flow is measured and totalized. This ensures the required filling quantity regardless of the set flow rate.

If the dust was not ignited during this test, the next test is automatically started after a short refill with the gas mixture.

See: 3.4.4 General test procedure: The dust was not ignited



The parameters „*quantity of gas mixture*“ and „*loss of gas mixture*“ can be changed if necessary. See: **3.5.4 Test - Settings**

### 3.5.4 Test - Settings

Requires the authorization: „System settings“ (Administrator or Service)

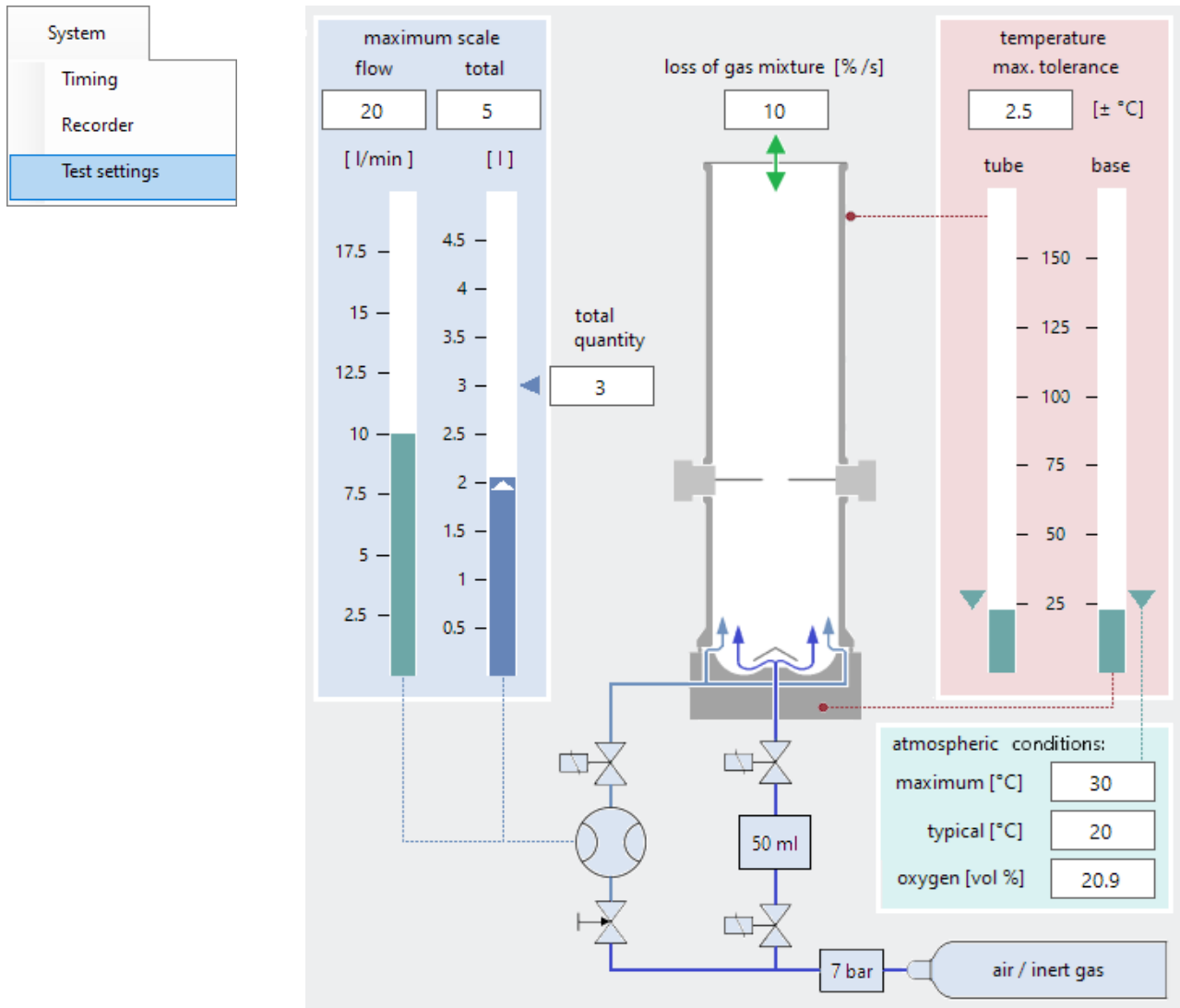

gassing	scale flow scale total total quantity loss of gas mix	for the gas flow [liter/min] for the filling quantity [liter] filling quantity of gas mixture [liter] estimated gas loss [% /s ]
temperature	max. tolerance	permissible temperature tolerance [± °C]
atmospheric	maximum* typical* oxygen	maximum ambient temperature [°C] typical ambient temperature [°C] oxygen content of the environment [vol %]

\* If the MIKE apparatus is not located in an air-conditioned laboratory, the entry for the ambient temperature may need to be adjusted.  
 "Maximum" must always be greater than "typical".

### 3.6 Tables

#### 3.6.1 Series

Info		Atmospheric		Temperature		Oxygen		Series		Audit
	sn	T [°C]	O <sub>2</sub> [%]	conc.	IE [mJ]	tv set	tv eff	induct.	I (NI)	comment
<input checked="" type="checkbox"/>	1	20	20.9	900	30	120	122	1	1	
<input checked="" type="checkbox"/>	2	20	20.9	900	10	120	122	1	(10)	

Designations:

sn	= consecutive numbering of the test series
T[°C]	= temperature in °C
O <sub>2</sub> [%]	= oxygen content in vol%
conc.	= weight of dust sample in mg
IE [mJ]	= ignition energy
tv set	= set ignition delay time (set value)
tv eff	= measured ignition delay time (actual value)
induct	= inductance (0 mH or 1 mH)
I	= ignition in specified experiment
(NI)	= no ignition of the dust after: (Number of Non-ignitions)

Editing the table:

- this series are valid and will be evaluated. (to change, click on this field).  
Incorrect entries for the dust weight can also be corrected later.

#### 3.6.2 Audit

Info		Atmospheric		Temperature		Oxygen		Series		Audit
no	date	time	cause	event	value	username	signature	authorization		
1	19.12.2023	14:25	CC	New file created		CC	Ch. Cesana	Administrator		
2	19.12.2023	14:25	MIKE	MIKE Series no.	22001 . 1	SE	Serge Egger	Service		
3	19.12.2023	14:25	MIKE	Flash ID, Revision	MMCA, 2328	SU	Susan Unger	Supervisor		
4	19.12.2023	14:25	MIKE	Flash ID, Revision	MTCA, 2305	OP	Olga Prost	Operator		
5	09.06.2024	06:46	OP	Series added	1					
6	09.06.2024	06:47	OP	Series added	2					

All activities are automatically recorded. An example:

- 1 CC starts a new file and with it a new audit.
- 2..4 Firmware and serial number of the MIKE-apparatus are included.
- 5 ... Each series added by OP is logged



The data of the audit are stored manipulation proof in the MIKE-file.

### 3.7 Calibration

---

According to international standards, the equipment for determining the minimum ignition energy must be calibrated at regular intervals (at least every 12 months or after every major maintenance or repair). Therefore, Cesana AG conducts an international round-robin test (CaRo) every year.

- EN 13821: Determination of the minimum ignition energy of dust / air mixtures
- ASTM E2019-03: Standard Test Method for Minimum Ignition Energy of a Dust Cloud in Air

**Calibration method:** For each parameter of the CaRo dust, the mean value from the test results of the participating laboratories is calculated as a standard value with a scatter range. All apparatus whose results are within the given tolerance band meet the calibration and receive a certificate from us. In the case of systems with strongly deviating results, we will again be able to find and eliminate the causes of errors based on the experience with previous round robin tests.

**Procedure:** The test dust is selected, homogenized, packed and dispatched by Cesana AG. The test results received are continuously evaluated and published on the Internet. After the test period has expired, a detailed overall evaluation is carried out with the calculation of the standard values and the associated tolerance band. Those laboratories that have fulfilled the calibration receive a certificate. All results are then (anonymously) summarized in a table and sent to the participants.

#### Sample preparation for the calibration:

The results can only be compared when the sample preparation is the same. Therefore the test dust has been milled, homogenized and tightly packed.

**Please keep the container closed whenever possible.**



For the calibration: please test the sample „**as delivered**“.  
By no means, prepare the sample additionally.



For the calibration, only tests **with** inductance ( $L = 1\text{mH}$ ) must be carried out.

## 4. Utilities

### 4.1 Report

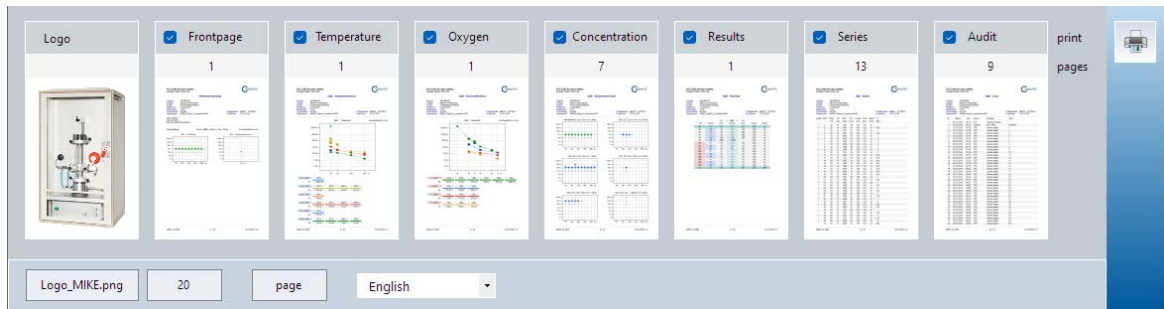

Select the **logo** for the report.  
 You can define your company logo here.  
 Requirements:  
 a) Bitmap ".png" file  
 b) Width of the logo in the report < 80mm.

Select the **language** for the report.  
 The program comes with some translation files.  
 These can be easily adapted to other languages.  
 See: [4.2 Translations](#)

The original width of the bitmap is automatically reduced to the width defined here when printing.



**REMBE® Research+Technology Center GmbH**

Test center Brilon

**Minimum Ignition Energy**

Product: **Niacin CaRo18**  
 Order: 18-0255-04  
 Customer: Cesana AG  
 Reason: Calibration-Round-Robin  
 Median: 21um  
 Preparation: tel quel  
 Filename: Demo\_Atmospheric.MIE



Apparatus: MIKE3 22001.1  
 Created: 18.08.2020

---

Atmospheric **1 mJ < MIE < 3 mJ / Es = 1.2 mJ** with Inductance L=1mH

MIE / Concentration

MIE / Ignition delay time tv

your comment ...

T [°C]	O2 [%]	E1 [mJ]	< MIE <	E2 [mJ]	tv [ms]	Induct.
20	20.9	1	1.2	3	150	yes

## 4.2 Translations

In the MIKE program, German and English are permanently programmed for the test report and user information. In addition, translation files are supplied in other languages. If your language is not listed, you can add your translation file using the following instructions.

### 4.2.1 Report

Target: test report in a different language. In the following example in French.

1. Open the Excel sheet '**M4\_Repo\_Example.xlsx**' and write your translation in the 2nd column.

2	Filename:	M4_Repo_Francais.txt	integrated in software
3			
4	Des {key}	Francais	English
5	{Head_MIE}	Energie minimale d'inflammation	Minimum Ignition Energy
6	{Head_Temp}	EMI - Influence de la température	MIE - Influence of Temperature
7	{Head_Oxygen}	EMI - Influence de l'oxygène	MIE - Influence of Oxygen
8	{Head_Conc}	EMI - Concentration de poussière	MIE - Dustconcentration
9	{Head_Results}	EMI - Résultats	MIE - Results
10	{Head_Series}	EMI - Séries	MIE - Series
11	{Head_Audit}	EMI - Audit	MIE - Audit
12	{MIE}	Energie minimale d'inflammation	Minimum Ignition Energy
13	{MIEshort}	EMI	MIE

2. Copy both fields with the keywords {...} and their translations into the clipboard and insert them into the **Microsoft Editor**.

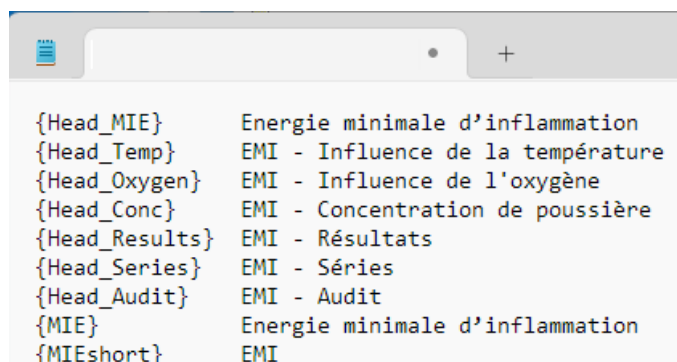

3. Save the file as "**M4\_Repo\_Francais.txt**".  
The file name must begin with "**M4\_Repo\_**".  
Start the MIKE program.  
The newly added language is displayed in **Settings / Setup 1** and in **Report**.  
All characters supported by the Microsoft operating system can be used.  
Example: M4\_Repo\_日本語.txt

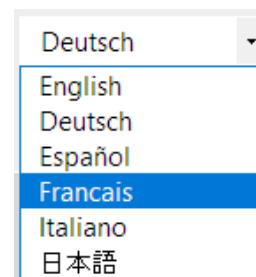

**4.2.2 Information**

Target: Messages and instructions for the user in another language.  
 The following example is in French.

1. Open the Excel sheet '**M4\_Info\_Example.xlsx**' and write your translation in the 2nd column.

2	Filename:	M4_Info_Francais.txt	integrated in software
3			
4	<b>key</b>	<b>Francais</b>	<b>English</b>
5	{GoBack}	retourner	go back
6	{GoNext}	prochaine étape	next step
7	{SaveSettings}	enregistrer les paramètres et quittez	save settings and close
8	{SelectDevice}	choisir l'interface CAN	select a CAN-device
9	{CANnumber}	changer le numéro de l'interface CAN	change number of CAN-device
10	{Cancel}	annuler	cancel
11	{CancelEsc}	Annuler (touche Esc)	cancel (Esc key)

2. Copy both fields with the keywords {...} and their translations into the clipboard and insert them into the **Microsoft Editor**.

```
{GoBack}      retourner
{GoNext}      prochaine étape
{SaveSettings} enregistrer les paramètres et quittez
{SelectDevice} choisir l'interface CAN
{CANnumber}   changer le numéro de l'interface CAN
{Cancel}      annuler
{CancelEsc}   Annuler (touche Esc)
```

3. Save the file as "**M4\_Info\_Francais.txt**".  
 The file name must begin with "**M4\_Info\_**".  
 Start the MIKE program.

The newly added language is displayed in **Settings / Setup 1**

All characters supported by the Microsoft operating system can be used.

Example: M4\_Info\_日本語.txt

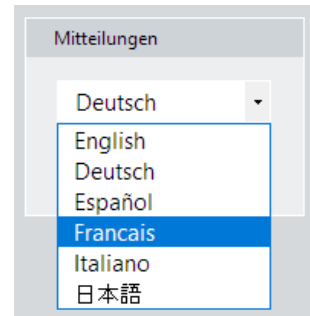

The on-screen texts remain unchanged in English. However, all the information important to the user is translated and displayed in their language. Examples:

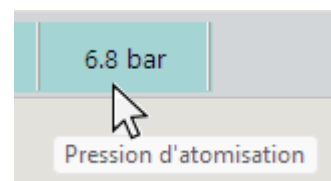
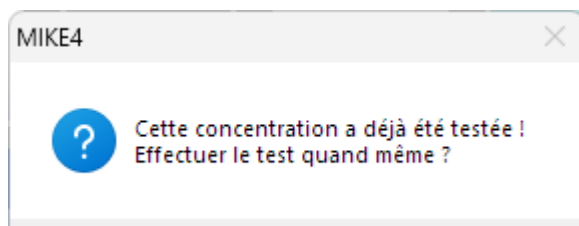

### 4.3 Export



Data and graphics can be easily exported to other programs.

First select the page to be exported:

(*Info, Atmospheric, Temperature, Oxygen, Series, Audit*).

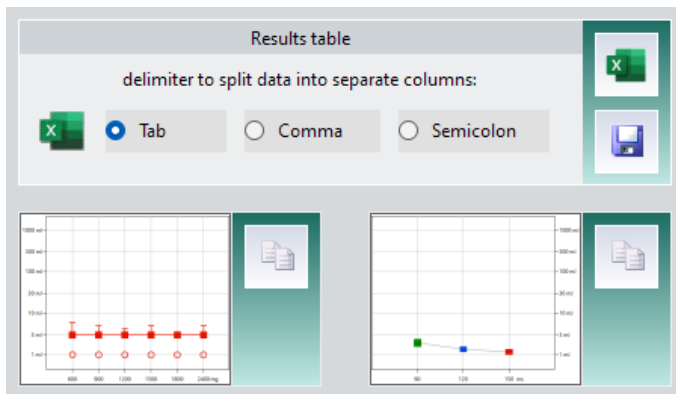

The data is copied to the Windows clipboard according to your specifications and can be easily pasted from there into other Windows programs. e.g. Excel, Word.

Alternatively, the data can be saved in a text file.

### 4.4 Info

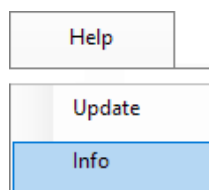

This utility shows an overview of the most important settings, the date of the files and information about your PC and its operating system.

For software problems, please copy this information to the clipboard, paste it into an email and send it with a description of the problem to:

[info@cesana-ag.ch](mailto:info@cesana-ag.ch)

## 4.5 Update

The “**Update**” menu is only available to users with administrator or service rights.  
The update is performed automatically. Existing software settings are retained.

**A** Your PC is connected to the internet. The update can be carried out immediately:

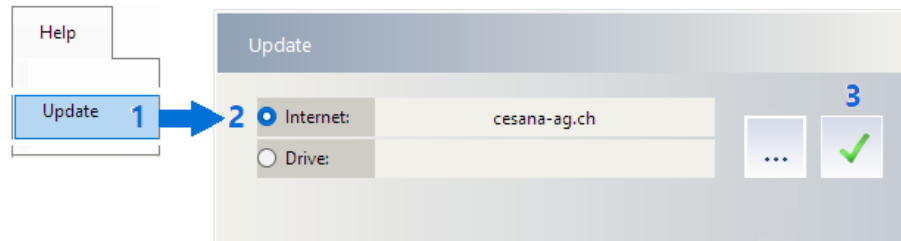

**B** Your PC is not connected to the internet::

Send an e-mail to: [info@cesana-ag.ch](mailto:info@cesana-ag.ch)

You will receive a link from us for downloading the file(s).

Extract the file “**CAG\_Updates.zip**” into a temporary directory or on a USB stick.

1. Start the update in the MIKE program.
2. Select “**Drive**” as the update source.
3. Search for the “**Updates**” directory.
4. Start the update.

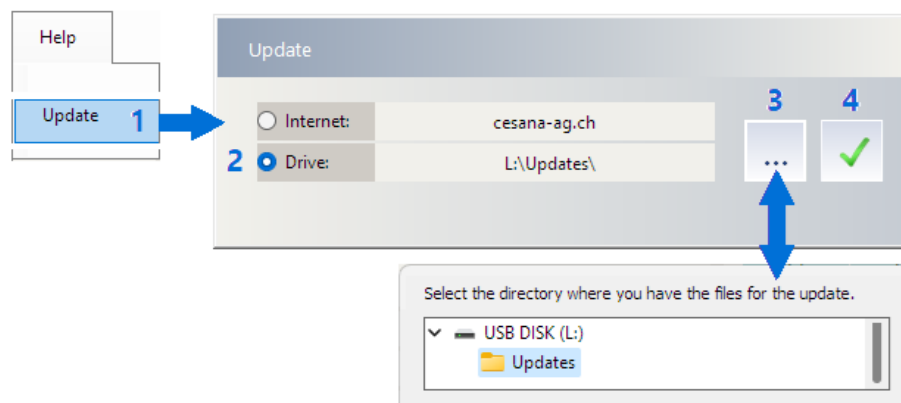

Participants in the annual CaRo calibration ring trial receive a USB stick with the latest software updates. Then enter the directory with the USB stick, e.g. **L:\Updates** in the **Drive** field and start the update.

## 4.6 Flash-Programming

If the following message appears after an update, the flash program needs to be updated.

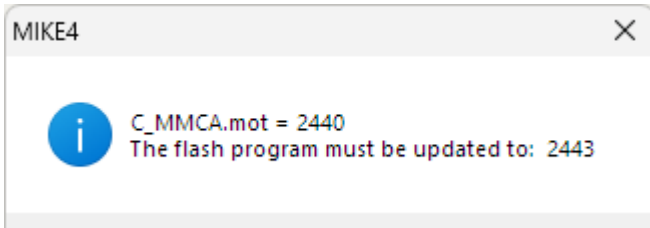

The “*CAN modules*” menu is only available to users with administrator or service rights.

Procedure:

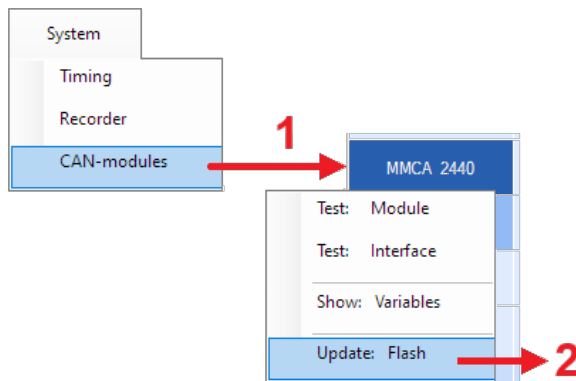

Search for flash file *C\_MMCA.mot*.

flash	pcb - board	identity	revision
current	MMC81A	C_MMCA	2440

**3**

Open the latest flash file

filename	date	size
C_MMCA.mot	08.11.2024	92 KB

**4**

The flash files are usually in the MIKE4 program directory.

Compare revision date and if newer, program this file.

flash	pcb - board	identity	revision
current	MMC81A	C_MMCA	2440
new	MMC81A	C_MMCA	2443

filename	lines loaded	lines written	time
C_MMCA.mot	1930	0	00:00

**5**

flash	pcb - board	identity	revision
current	MMC81A	C_MMCA	2440
new	MMC81A	C_MMCA	2443

filename	lines loaded	lines written	time
C_MMCA.mot	1930	461	00:22



*pcb-board* and *identity* must be of the same type.  
(revision = year / week)

## 5. Check the MIKE

### 5.1 Error messages



#### 1. Charge too low? No spark?

Thoroughly clean the electrodes and insulators and, if necessary, check the electrode spacing. If electrostatically charged dust adheres to the glass tube, the resulting electrical field makes the spark more difficult. The spark jumps with a delay and its energy is often too low due to corona losses. The glass tube must be rinsed with water (to reduce surface resistance). Then repeat the experiment with a fresh dust filling.



#### 2. Charge too high?

The internal spark monitoring system reports that the charge transferred by the spark and thus the energy was too high. If this error occurs repeatedly and with only one energy value, there is a suspicion of a defective high-voltage capacitor!



#### 3. Deviation of $t_v > 10$ ms

When triggered by moving electrodes (10mJ ... 1J), the mechanism is probably dirty and stuck together. Clean the piston rod and, if necessary, oil them a little. Press the "ME" key several times..

When triggered by the high-voltage relay (1mJ, 3mJ), the cause of the delayed spark jump must be sought in the electrical field that has built up. The glass tube should be rinsed out with water (to reduce surface resistance). Then repeat the experiment with a fresh dust filling.



#### 4. Check: Cylinder ...

Each cylinder has a position sensor and the position of the cylinder is monitored. For further diagnosis use the program [5.4 Check: IO - Port](#)

activate and deactivate the cylinder in question. Does the position display change?

- a) The position sensor is misaligned or defective.
- b) The cylinder does not reach the required position.

A visual inspection is recommended for further diagnosis. See: [Service - Manual](#)



#### 5. Pressure too low

Check the compressed air connection (7 bar?)

## 5.2 Check Ignition

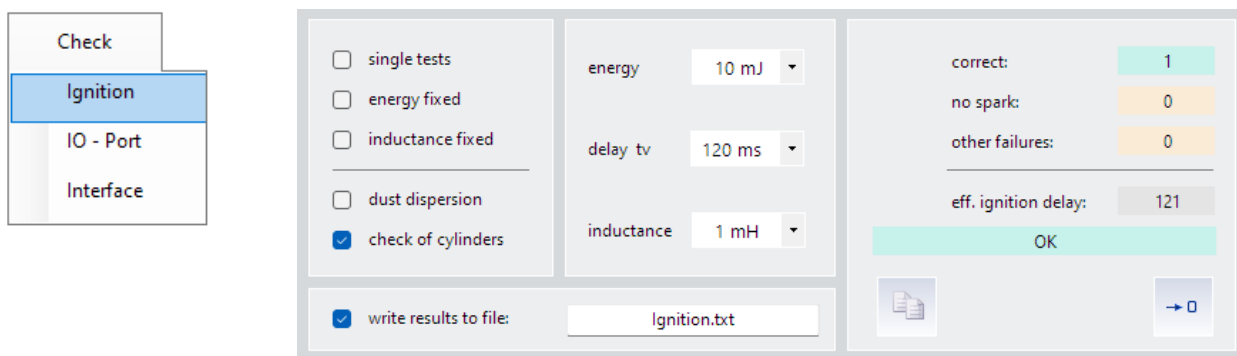

A distinction is made between the specified ignition delay time (delay tv = **tv set**) and the time measured when the spark occurs (eff. Ignition delay = **tv eff**).



Start and wait for at least 20 tests.  
Then stop the test procedure.



Copy the recording to the clipboard and paste it into a word processing or e-mail program.

write result to file:

If activated, the file "Ignition.txt" is in the MIKE directory.

Recording  
(example)

MIKE:	Test of ignition		04.02.2025			
No.	IE[mJ]	Ind	tvSet	tvEff	MEcorr	
1	1	0	120	122	0	OK
2	3	0	120	121	0	OK
3	10	0	120	107	0	Deviation of tv > 10ms
4	30	0	120	125	4	OK
5	100	0	120	123	7	OK
6	300	0	120	122	8	OK
7	1000	0	120	121	7	OK
8	1	1	120	121	7	OK
9	3	1	120	121	7	OK
10	10	1	120	120	7	OK
11	30	1	120	123	9	OK
12	100	1	120	122	8	OK
13	300	1	120	121	7	OK
14	1000	1	120	122	8	OK
15	1	0	120	120	8	OK
16	3	0	120	121	8	OK
17	10	0	120	120	8	OK
18	30	0	120	123	9	OK
19	100	0	120	122	8	OK
20	300	0	120	121	7	OK

Further checks at

### Charge too low ? No spark?

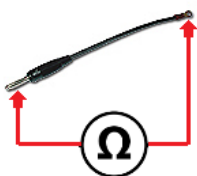

Many movements of the electrode on the left-hand side can lead to a conductor break in the connection cable. This can be easily checked with an ohmmeter. Electrical continuity must be indicated. Otherwise the cable SP700513 must be replaced.

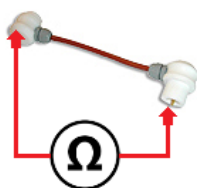

The cable on the high-voltage side may also be interrupted due to frequent movement. This can be easily checked with an ohmmeter. Electrical continuity must be indicated. Otherwise the SP700400 cable must be replaced.

### 5.3 Check IO - Port

With this test program you have a direct access to all cylinders, valves and relays of the MIKE.

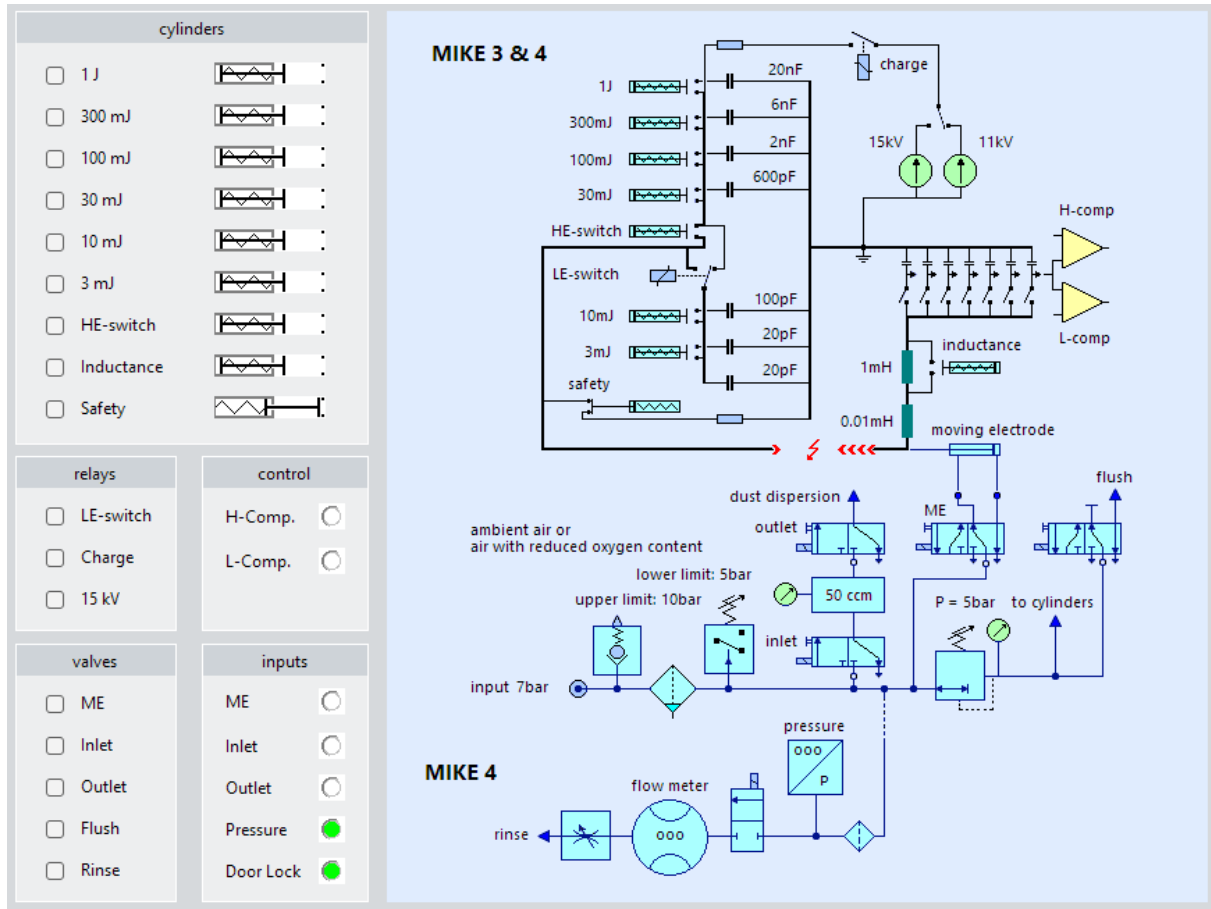

#### Group "cylinders"

Safety:	Inverse cylinder: In the home position, the HV output is grounded.
Induct.:	High-voltage switch for jumpering the 1 mH inductance.
HE-Sw.:	High-voltage switch: 30mJ...1J busbar / HV output.
3 mJ....1 J:	High-voltage switch for the particular energy level. (The capacitor for the 1 mJ spark is always connected)

#### Group "relays"

LE-Switch:	High-voltage relay
Charge:	Charging relay
15 kV:	Switch: 11 / 15 kV

#### Group "control"

H-Comp.:	Upper limit
L-Comp.:	Lower limit

#### Group "valves"

ME:	Moving electrode
Inlet:	Inlet valve
Outlet:	Outlet valve
Flush:	Purging

#### Group "inputs"

ME:	Moving electrode
Inlet:	Inlet valve
Outlet:	Outlet valve
Pressure:	Pressure monitoring
Door Lock:	Door locking

## 5.4 System Timing

Requires the authorization: „System settings“ (Administrator or Service)

The times in the MIKE test sequence can be freely defined within wide limits. Normally, there is no need to change these times, because the optimum settings are already predefined. If necessary, use the "default" key to set all times to the optimum standard values.

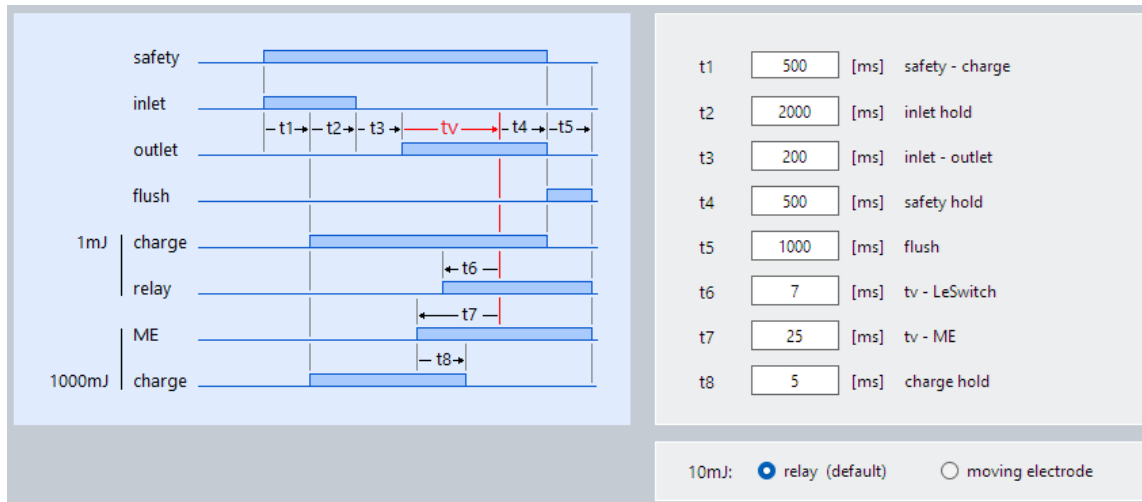

- t 1** Start of cycle: After this time has elapsed, all pneumatic cylinders must have reached their correct position.
- t 2** Opening time for the inlet valve (Inlet): At the same time, charging time of the capacitors. This time must be sufficient to allow filling of the pressure vessel and also ensure reliable charging of the largest capacitor.
- t 3** Delay time inlet-outlet valve (Inlet-Outlet): The inlet valve must be completely closed before the outlet valve opens.
- t 4** Hold time of the outlet valve.
- t 5** Purging (Flush): The holder of the moving electrode is cleaned with compressed air.
- t 6** Triggering by high-voltage relay: This time-entry compensates the switching time of the relay so that sparkover occurs at the desired  $t_v$ -time.
- t 7** Triggering by moving electrode: This time-entry compensates the mechanical movement time of the electrode so that sparkover occurs at the desired  $t_v$ -time.
- t 8** Charge relay hold: This time-entry compensates the delay in the mechanical movement of the electrode so that the loss of charge due to corona current is reduced.
- 10mJ** In principle, the type of triggering can be changed at  $IE=10mJ$ . However, we recommend to leave the default value (relay).

## 5.5 Temperature recording

Requires the authorization: „System settings“ (*Administrator or Service*)

The temperatures can be recorded for monitoring purposes. This is done in the background and has no influence on the operation of the MIKE.

### Example of a recording:

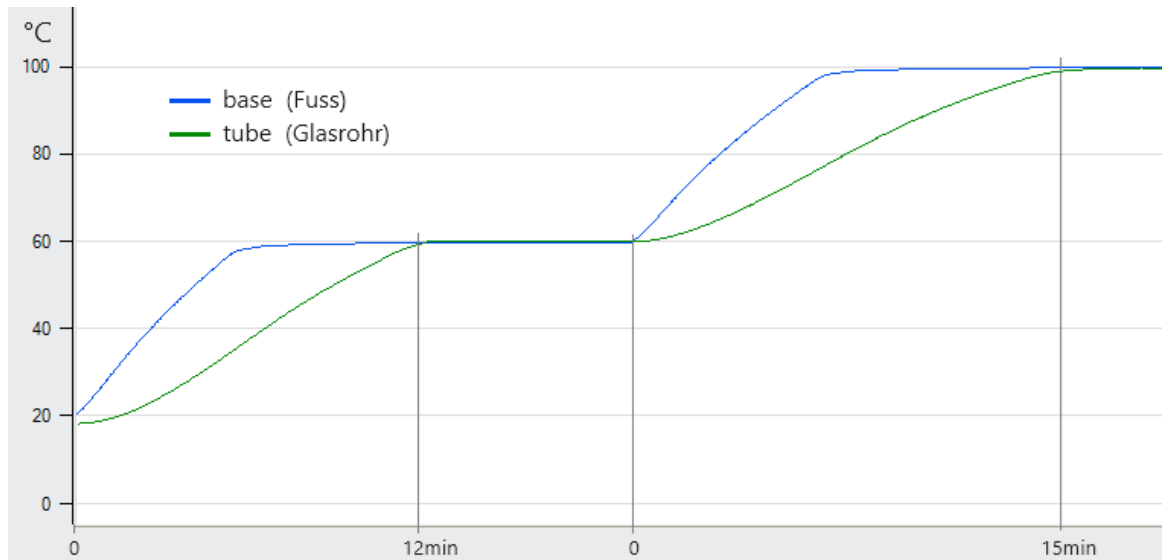

### New recording:



When a new file is opened, the sampling time, i.e. the time interval between two measured values, is defined. The maximum file length (maximum length) depends on the sampling time.



After opening a new file, data acquisition is still switched off. Data acquisition must be explicitly switched on by this command.

**Endless recording:** The length of the recording corresponds to the width of overview. New data is then added at the end and the oldest data is deleted - comparable to an endless tape.



### Overview

Draw a frame around the area of interest to enlarge it.



### Part view

Each measuring point is recorded with the date and time. An interruption in the recording (e.g. stop of the recording) is indicated by a vertical gray line.

<b>1</b>	width of overview,	sampling
	<input checked="" type="radio"/> 12 hours,	1 sec
	<input type="radio"/> 1 day,	2 sec
	<input type="radio"/> 5 days,	10 sec
	<input type="radio"/> 10 days,	20 sec
<input type="radio"/> 14 days,	30 sec	
<b>2</b>	<input checked="" type="checkbox"/> endless record	
<b>3</b>	Start a new record	<input checked="" type="checkbox"/>

**Temperature control**

The temperature of the metal base for the dust dispersion is easy to regulate. Achieving a homogeneous temperature distribution in the glass tube, on the other hand, is very complex. This cannot be achieved with a simple heating jacket around the glass tube. The MIKE4 therefore uses aluminum heating shells with a defined air gap to the glass tube. The surface temperature of the glass is measured and controlled in cascade to the heating shell temperatures. The front heating tray can be turned to the side for a quick change from the glass tube.

Principle diagram of the temperature control loops:

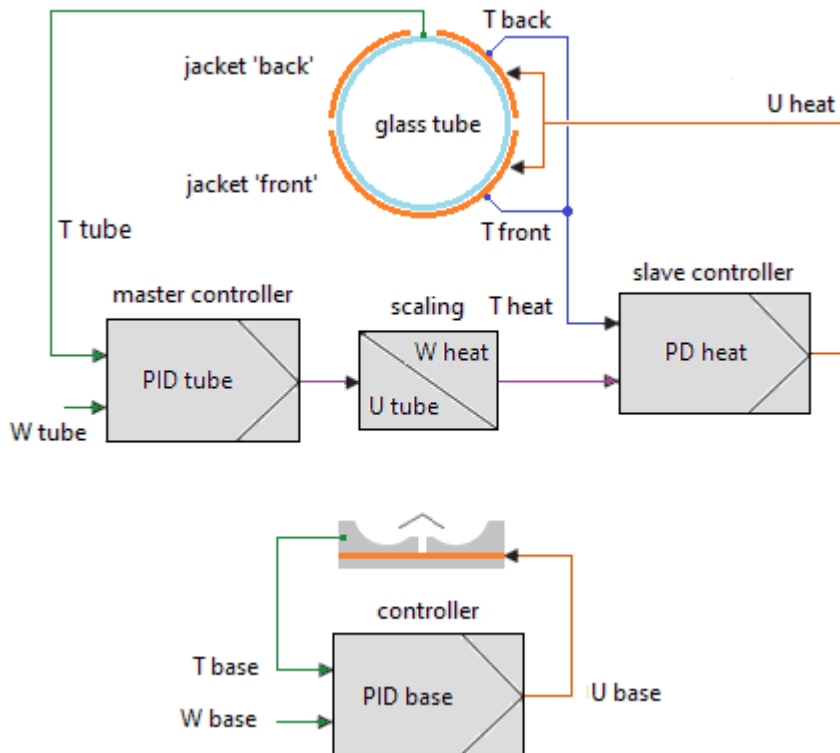

## 6. References

ASTM E2019	Standard Test Method for Minimum Ignition Energy of a Dust Cloud in Air
Bartknecht, W.	Dust-Explosions, Course, Prevention, Protection. Springer-Verlag Berlin, Heidelberg, New York, 1989
Bartknecht, W.	Explosionsschutz; Grundlagen und Anwendung Springer Verlag, Berlin, Heidelberg, New York 1993
Cesana C. Maman L. Schwaninger M.	Extension of the Applicability of MIKE 3 to Determine the Minimum Ignition Energy of Powders under "Non-Atmospheric" Conditions. Chemical engineering transactions vol. 75, 2019
Cesana C. Eiche M. Schwaninger M.	Quality Management in the Determination of Safety Characteristics Chemical engineering transactions vol. 75, 2019
Chaudhari P. Ravi B. Bagaria P. Mashuga C.	Improved partial inerting MIE test method for combustible dusts and its CFD validation. Process Safety and Environmental Protection 122 (2019) 192–199
Eckhoff, R.K.	Dust Explosions in the Process Industries, Butterworth-Heinemann Ltd., Oxford, 1991
EN 13821	Explosionsfähige Atmosphären - Explosionsschutz - Bestimmung der Mindestzündenergie von Staub/Luft-Gemischen, November 2002
Glarner, Th.	Temperatureinfluss auf das Explosions- und Zündverhalten brennbarer Stäube, Diss. ETH Zürich Nr. 7350, 1983
Glor M. Schwenzfeuer K.	Einfluss der Sauerstoffkonzentration auf die Mindestzündenergie von Stäuben VDI Berichte, Nr. 1272, pp. 119-134, 1996
Jaeger, N. Siwek, R:	Prevent Explosions of Combustible Dusts, Chemical Engineering Progress, Vol. 95/No. 6, June 1999
Lüttgens G, Glor, M.	Understanding and Controlling Static Electricity. Expert Verlag, Ehningen bei Böblingen, 1989
Pellmont,G	Explosions- und Zündverhalten von hybriden Gemischen aus brennbaren Stäuben und Brenngasen, Diss. ETH Zürich Nr. 6498, 1979
Siwek, R. Cesana, C.	Ignition behaviour of Dusts, 28th Loss Prevention, Atlanta, 1994
Van Laar, G.F.M.	"Influence of moisture content on the minimum ignition energy (MIE) of dust/air mixtures". Report on the working group Minimum Ignition Energy, Prins Mautits Laboratorium TNO, November 1983